HOGGI[®]



CE

SUPRA 2.0 User manual

en

1	Model identification & basic configuration	3
1.1	Model identification	3
1.2	Basic configuration	4
1.3	Environmental conditions	4
2	Common information	5
2.1	Preface	5
2.2	Application	5
2.3	Declaration of conformity	5
2.4	Terms of warranty	6
2.5	Servicing and repairs	6
2.6	Duty to inform serious cases	6
2.7	Product safety / product recalls	6
3	Safety instructions	7
3.1	Meaning of symbols	7
3.2	Common safety instructions	7-10
4	Delivery and preparing for use	11
5	Adjusting and adaptation possibilities	16
5.1	Brake <i>HOGGI</i> light	16
5.2	Seat width	16
5.3	Seat height, seat depth, seat angle	16
5.4	Camber	17
5.5	Backrest height	17
5.6	Backrest angle (rigid)	17
5.7	Backrest angle (with an angle-adjustable back)	17
5.8	Active degree	18
5.9	Anti-tip	18
5.10	Detaching wheels with quick-release axles	19
5.11	Pneumatic tyres / PU-tyres	19
5.12	Push-rims	19
6	Accessories	20
6.1	Lower leg length	20
6.2	Lap belt	21
7	Transport	21
7.1	In the trunk (luggage space) of a car	21
7.2	Using SUPRA 2.0 for bus transport	21
7.3	General	21
7.4	Securing the wheelchair during bus transport	22
7.5	Buckle up the wheelchair passenger	23
7.6	Transfer - getting into or out of the wheelchair	25
7.7	Anti-tippers to override steps	258

Storage 26

9 Recycling and disposal _____ 26

10 Maintenance _____ 27

11 Specifications _____ 28

1 Model identification

1.1 Model identification

(The label of **SUPRA 2.0** is placed on the axle tube)

The image shows three identical labels for a HOGGI SUPRA 2.0 axle tube. Each label contains the following information:

- Colour code:** 3281-00SB-XXX
- Item number:** MD
- Size / Model:** SUPRA 2.0
- Serial number:** 202105/03 2021178999
- CE label:** CE XXXkg
- Classification / Product name:** HOGGI SUPRA 2.0
- Manufacturing date:** 2021/05/03
- Maximum load / load capacity:** max. load
- Manufacturer:** HOGGI GmbH
- Place of manufacture:** 56235 Ransbach-Baumbach
- Year of manufacture:** 2021
- UDI Code:** (01)04047349096062(21)202178999

Callouts on the right side of the labels point to these specific fields:

- Colour code
- Item number
- Size / Model
- Serial number
- CE label
- Classification / Product name
- Manufacturing date
- Maximum load / load capacity
- Manufacturer
- Place of manufacture
- Year of manufacture
- UDI Code

1.2 Basic configuration

- Powder coated rigid aluminium frame (powder coated; growth capacity in seat depth)
- 3 Sizes::
 - Size 1: Seat width 24-34cm in 2 cm steps, Seat depth 19-34 cm
 - Size 2: Seat width 28-38cm in 2 cm steps, Seat depth 20-39 cm
 - Size 3: Seat width 28-38cm in 2 cm steps, Seat depth 25-44 cm
- Rear wheels including push-rims (removable via quick-release axle)
- Clothes cover
- Wheel camber selective 3°, 6° or 9°
- Backrest angle: 70° bis 105° adjustable
- Adjustable back cover
- Seat height front: 38 cm to 51 cm
- Seat angle: 0° - 10°
- Convertible to other seat widths
- Footrest: standard
- Weight limit: 60 kg (size 1), 75 kg (size 2), 100 kg (size 3)

1.3 Environmental conditions

Environmental factors such as temperature and humidity can damage the wheelchair. The manufacturer recommends not condensing the **SUPRA 2.0** at ambient temperatures between -20 ° C and + 40 ° C and a humidity of 5 to 100%.

Caution: Prolonged exposure to the sun may cause parts of the wheelchair to become hot. Be sure to!

2 Common information

2.1 Preface

Thank you for selecting the **SUPRA 2.0** wheelchair. We have designed this high-quality product to make your life safer and easier, and we've included this manual to help you use and care for it.

Please read the following instructions to make sure you use this product as recommended. If you have any further questions, or if you have any problems, please contact your healthcare provider. We hope that **SUPRA 2.0** meets your expectations.

We reserve technical modifications regarding the specified model in this manual. Before using the wheelchair the first time, this manual has to be read and understood by patient and support personnel in order to ensure a safe handling with the wheelchair

2.2 Application

The **SUPRA 2.0** wheelchair is designed solely for individual indoor and outdoor use by children and adolescents (sizes see „Specifications“ p. 28) who are unable to walk or who have a walking impediment, and can be operated by the patient or by another person.

Assistance may be required due to:

- Paralysis (paraplegia / tetraplegia or tetraparesis)
- Loss of limbs (dysmelia/lower limb amputation)
- Infantile/spastic cerebral palsy
- Spina Bifida
- Muscle and nerve disorders
- Imperfect osteogenesis
- Poliomyelitis

The **SUPRA 2.0** wheelchair is able to be used for further service. For further service the product has to be cleaned and sanitised efficiently. Afterwards the product has to be checked concerning condition, wearout and damage by an authorised technician. All damaged and inappropriate parts need to be changed. Please see also the service manual for detailed information.

2.3 Declaration of Conformity

HOGGI GmbH as manufacturer with sole responsibility declares that the **SUPRA 2.0** wheelchair as a whole conforms to the basic safety and performance requirements in accordance with Annex I to Regulation (EU) 2017/745 of the EU Parliament and of the Council.

Applicable harmonized standards have been applied. **SUPRA 2.0** meets the requirements of ISO 7176-8, DIN EN ISO 12182 and DIN EN ISO 12183.

2.4 Terms of warranty

Warranty applies only when the product is used according to the specified conditions and for the intended purposes, following all manufacturer's recommendations.

The manufacturer is not responsible for damages caused by components and spare parts not approved by the manufacturer.

See also § 8 of terms and conditions on: www.hoggi.de

2.5 Service and repairs

Service and repairs on the **SUPRA 2.0** wheelchair should only be carried out by authorized **HOGGI** dealers. Should any problems arise, please contact the dealer who supplied your **HOGGI**. Authorized dealers only fit original **HOGGI** spare parts.

Spare parts and exchange units are available throughout the life of the product, but only a maximum of 5 years after the last product in the series was sold.

The wheelchair is made for the first user according to customer requirements. Therefore, no replacement wheelchair is available in the initial configuration. To ensure correct delivery of spare parts, the serial number of your wheelchair is needed.

We would be happy to help you find a dealer near you.

You can reach us at: info@hoggi.de

2.6 Duty to inform serious cases

All serious incidents that have occurred in connection with the product must be reported to the manufacturer, the specialist trade and the responsible authority.



For Preparing, repair and service, the following tools are required:

- Allen wrench, size: 3 mm, 4 mm, 5 mm
- Socket wrench, size: 8 mm, 9 mm, 10 mm, 13 mm, 17 mm
- Spanner, size: 8 mm, 9 mm, 10 mm, 11 mm, 19 mm, 22 mm, 24 mm
- Slotted screwdriver
- Needle nose pliers
- Torque wrench



Further SUPRA 2.0 documentation:

- Service manual
- Spare parts catalogue

3 Safety instructions

3.1 Meaning of symbols

**Caution!**

Warning of possible danger of accident and injury. Warning of possible technical damage.

**Information!**

About use of product.

**Information!**

For service-personnel.

**Attention!**

Read manual before use!

3.2 Common safety instructions

Read manual completely before use! Familiarize yourself with handling and functions of the wheelchair before use and practice the handling.

You are responsible for the safety of your child. The safety of your child could be affected if you do not follow the instructions of this manual. Nevertheless not all possible circumstances and unpredictable situations can be covered by this manual. Reason, care and circumspection are not features of the product, they are required of persons, who use the wheelchair or attend it. The person, who is using the wheelchair and its accessories should understand all instructions. It must be explained to every other person using the wheelchair and its accessories. If instructions are not clear and further explanations become necessary, or if you have further questions please contact your **HOGGI** dealer.

Practise with the new wheelchair on even, straightforward terrain first, together with the child. Together with the child, learn how the wheelchair reacts when the centre of gravity shifts; for example on slopes or inclines or when clearing obstacles such as steps and curbs. This should be done only with assistance from another person.

Using an anti-tip is strongly recommended for inexperienced wheelchair users.



Strap in your child at all times, when it is in the wheelchair.



HOGGI points out, that any use beside the typical use can be dangerous. The wheelchair is not suitable for jogging, running, skating or similar activities. Swivelling front wheels tend to wobble at higher speed, which can cause a sudden stop and tip over of the wheelchair. Use the wheelchair only at regular walking speed. Under no circumstances leave the handle bar while pushing and never push the wheelchair away.



The wheelchair should only be used on solid level ground.



Use your wheelchair as intended by the manufacturer. For instance, do not drive into obstacles (including steps, curbs, piece of furniture).



To clear obstacles such as steps and curbs, tilt the wheelchair onto the rear wheels (pull it backwards to go up; to descend, slowly lower it forward).

If only one attendant is available when ascending or descending stairs, an incorrectly set anti-tip (if mounted at all) can lead to severe falls. Adjust the anti-tipper so that it does not come in the way of the steps during transport. Afterwards, swing the anti-tipper back to its operational position.



Do not go up or down stairs without the assistance of another person. If devices such as ramps or elevators are available, please use them. Ensure that the anti-tip (if mounted) is outside the danger-area. If wheelchairfriendly access is missing, two attendants must carry the wheelchair over the obstacle.

The wheelchair should be lifted only by touching tighten parts of the frame (on the side frame above the front wheels and on the push handles which are fixed on the backrest base - if brakes are closed, also the push-rims can be used for lifting).



When ascending slopes or ramps and when crossing obstacles on upward slopes, always lean the wheelchair user's upper body far forward.

When descending slopes, do not drive without braking and reduce your speed. Reduced load on the casters due to centre of gravity shifting can cause the casters to flutter.



If you have to park on a slope, face the wheelchair uphill with the brakes engaged and ensure that the seat is in the upright position. There is a risk that the pushchair might tip over backwards if the seat is the reclined position.



Before leaving the wheelchair and before getting into and out of it, always lock the wheel locks.



- Don't use the footrest to get into and out of the wheelchair generally.
- Use the footrest with shoes only.



Depending on footplate settings and wheelchair geometry, the wheelchair may tip over if the user boards the chair using the footplate. First practise boarding the chair with the child and an attendant who can secure the wheelchair, and modify footplate and seat height settings if the chair has a tendency to tip over. The footrest must not be used to get into the wheelchair. Fold up the footrest before getting on.



The effectiveness of the wheel lock and the overall driving quality are dependent on adequate air pressure. With properly inflated rear wheels and even tyre pressure on both sides, your wheelchair is much easier to operate and manoeuvre. Before starting to use your wheelchair, check that the tyres are inflated correctly. The required air pressure is printed on the side of the tyre. For rear wheels, it should be at least 6 bar.



All brakes acting on the tyres do not serve as service brake but are only designed as parking brake (wheel lock). The wheel locks must not be used as driving brakes for slowing down the wheelchair, as in extreme cases, the abrupt stopping of the wheelchair can lead to falls.



Please keep packaging material away from children. Plastic packaging presents the danger of suffocation..



Disposal of waste: The packaging material as far as metal, aluminium and plastic parts can be recycled. The recycling must be operated according to the national and legal terms.



Check the condition of the product if the packaging shows damages.



Never leave your child unattended in the wheelchair even when they are strapped in and the brakes engaged.



In the dark, the user should wear light clothing or clothing with reflectors in order to improve visibility. Ensure that the reflectors are installed on the sides and rear of the wheelchair. We also recommend installing active lighting.



Extreme settings (e.g. shortest wheelbase and seat in the backmost position) combined with an unfavourable body posture can cause the wheelchair to tip even on level ground. It is imperative to activate the anti-tips.



When driving uphill, the static stability can be less than 10 °. Attaching heavy bags or other weight to the push handles can adversely affect stability.



Adjustments with a high active degree demand a practised driver and the use of an anti-tip.



Under no conditions should the anti-tip(s) assume the function of transport wheels, for example to transport a person in the wheelchair with the rear wheels removed. The antitips must audibly lock in place, before it is able to bear loads. Firm seating must be verified by the user or by an attendant.



The maximum load for **SUPRA 2.0** is 60 kg (size 1), 75 kg (size 2), 100 kg (size 3).



Accessories and add-ons reduce the maximum load proportionately.



Attention!

We recommend that, wherever and whenever possible, users transfer to the seats installed in the motor vehicle and use the corresponding vehicle restraint systems, because this is the only way to ensure optimum protection of the passengers in case of an accident. **SUPRA 2.0** is admitted for use as a seat in a motor vehicle.



Be careful in case of extreme temperatures. The wheelchair can heat up significantly in the sun or in the sauna. In extreme cold, there is a risk of hypothermia. **SUPRA 2.0** is not suitable for use in the sauna. Slowing down from high speeds or when descending longer slopes tends to heat up the hands and fingers, especially if using aluminium push rings.

When using the wheelchair outdoors, leather gloves should be worn. Gloves provide the wheelchair user with a better grip and protect his or her fingers from dirt and hot metal. For sensitive skin, we recommend using gloves similar to those used in cycling (finger cots with a leather inside - but never wool gloves).



Always pay attention to the correct setting of the thru axles on the rear wheel. The rear wheel must not be able to be removed if the button on the thru axle is not pressed.



Neither seat nor backrest height may be exceeded.



The assembly of a seat shell is only permitted within the specified seating area. The manufacturer of that new product combination has to test the stability and the adherence of the maximum load before commissioning. When applying seat and backrest panels always use upholstered seat cushions to avoid to avoid dents.



Avoid reaching into any clamping range.
Danger of clamping exist in following assembly groups:
- Brake lever (if **SUPRA 2.0** is supplied with fender with integrated brake system)
- Between brake lever and rear wheel



The wheelchair should be lifted only by touching tighten parts of the frame (on the side frame above the front wheels and on the push handles which are fixed on the backrest base - if brakes are closed, also the push-rims can be used for lifting).



The **HOGGI** seat cushion (Trevira CS) and the contoured seat cushion (Trevira CS) as well as the **HOGGI** nylon backrest abd seat cover are flame resistant referred to the EN 1021-1 and EN 1021-2 norm.



Please read to visually handicapped people the manual and info material - or use electric aids. Please download or read all **SUPRA 2.0** documents on our webside **www.hoggi.de**



Whenever you change any settings on the wheelchair, make sure that you firmly tighten any screws that have been loosened.



Always make sure that when transporting in the car, the tensile force per belt (max. 10 kg) must not be exceeded, otherwise damage can arise on the frame of the wheelchair.



Information about product safety or product recalls as well as all contact details are available on our website at **www.hoggi.de**.



4 Delivery and preparing for use

Your **SUPRA 2.0** wheelchair will be supplied completely mounted with removed rear wheels and if necessary removed anti-tippers.

Delivery in board: 730 mm (L) x 630 mm (W) x 630 mm (H)

Please check the condition of the product if the packaging shows damages.

Please remove the transport packaging carefully.

The original package contains the following parts:

- Wheelchair with mounted push-bar
- Rear wheels and quick-release axles unmounted
- Front castors already mounted in the front castor forks
- Already mounted anti-tip
- Additional accessories as ordered
(These have to be mounted by an authorized dealer)
- Instructions and list of tools required



To prepare the wheelchair for use please proceed as follows:

- Grip the head of the quick-release axle as illustrated and press the release knob.
- Whilst pressing the release knob, position the quick-release axle into the rear wheel bearing.



- Place the wheelchair onto the front castors and lift the wheelchair at the back clamp.
- Insert the rear wheel and the quick-release axle into the axle housing. Hold the spokes close to the wheel hub and press the release knob with your thumb. The rear wheel can then be easily slide into position.
- Make sure that the plug-in axle is securely locked in the receiving socket!



CAUTION!

Push each rear wheel to check that each quick-release axle is safely located.

If your wheelchair is supplied with an **anti-tip** it could be in hinged position for transportation.

- Place yourself behind the wheelchair and move the anti-tip with the foot downwards.



- Turn the anti-tip with the foot to the inside into the active position.



The active position is reached if the anti-tip is snapped audibly.

SUPRA 2.0 can also be equipped with two pre-assembled anti-tippers.



The illustration shows an anti-tip in the „active“ position.



The length of the tubes can be adjusted in three positions.

The anti-tip should be adjusted that it is 2-3 cm above the ground.



Swingaway of the anti-tip:

- Place yourself behind the wheelchair and move the anti-tip downwards with your foot.
- Turn the anti-tip with the foot to the inside until the inactive position is reached

The inactive position is reached if the anti-tip is snapped audibly.



The illustration shows an anti-tip in the „inactive position“.



If your **SUPRA 2.0** is equipped with the **angle-adjustable back**, it may be folded down for transport.



- Pull the release rope with one hand as shown and move the back construction backwards with the other hand.



- Engage both bolts audibly in the desired back angle position.



If your **SUPRA 2.0** wheelchair is supplied with **seat or back upholstery** from **HOGGI**, please proceed as follows:

- If necessary, check the already attached Velcro strips at the back.



- If necessary, check the already attached Velcro strips at the seat.

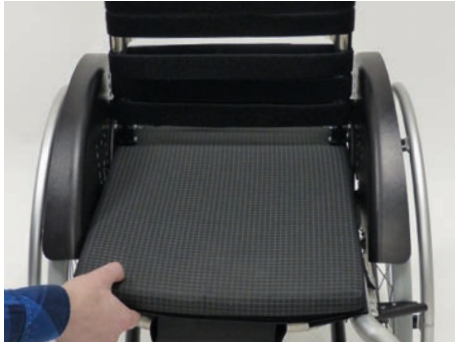

- Lay the seat cushion on the seat and the already fixed Velcro strips.
- Press the seat cushion onto the seat and the Velcro strips.



- Attach the seat cushion as shown (on the back) under the seat with the Velcro strips.



- Position the back cushion as shown.



- Press firmly the cushion on the pre-installed Velcro.



If your **SUPRA 2.0** is equipped with **push handles**, it is possible that they are in the lowest position for transport.

- Open the screw connections as shown.



- Use the other hand to move the push handle to the desired height.
- Close the screw connections.
- Do the same on the opposite side.



The wheelchair was built according to the customer order and the **lower leg length** was individually preset according to customer requirements.



- Loosen and remove the screw connections on both sides.



- Move the toe footrest to the desired position.



- Then tighten the clamping screws again.



Never use the footrest for getting in and out!

5 Adjusting and adaptation possibilities

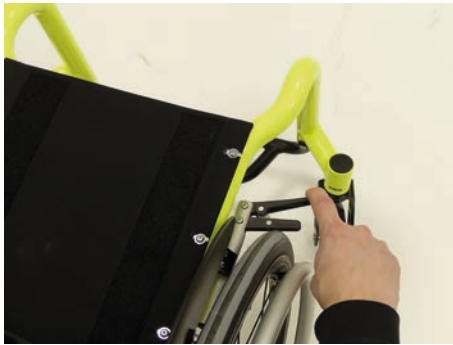

5.1 Brake *HOGGI* light

- To close the brake, push the brake lever with your forefinger backwards.



CAUTION!

All brakes acting on the tires do not serve as a slow down brake but are only designed as a parking brake (wheel lock). The wheel locks must not be used as driving brakes for slowing down the wheelchair, as in extreme cases, the abrupt stopping of the wheelchair can lead to falls.



- To open the *HOGGI* light brake, push the brake lever forward as shown.



CAUTION!

The effectiveness of the wheel lock are dependent on adequate air pressure. Before starting to use your wheelchair, check that the tires are inflated correctly. The required air pressure is printed on the side of the tires. For rear wheels, it should be at least 6 bar.



The illustration shows a closed *HOGGI* light brake.



5.2 Seat width

The **seat width** is adjustable in 2 cm steps by the dealer.



5.3 Seat height, Seat depth, Seat angle

Seat height, **seat depth** and **seat angle** will be adjusted on the base plates.

The **SUPRA 2.0** wheelchair will be built in accordance with the customer's order. It is possible for the dealer to modify the seat height, seat depth and seat angle of the rear wheels.



5.4 Camber

The **SUPRA 2.0** wheelchair can be supplied with rear wheels inclined (camber) 3° from the vertical. The illustration shows the camber adapter.

The illustration shows the camber adapter.



5.5 Backrest height

- The backrest height can be adjusted after loosening the marked screw connections (on both sides).

The **SUPRA 2.0** wheelchair will be built in accordance with the customer's order. It is possible for the dealer to modify the backrest height.



5.6 Backrest angle (rigid)

- The backrest angle can be adjusted in height after loosening the marked screw connections (on both sides).

The **SUPRA 2.0** wheelchair will be built in accordance with the customer's order. It is possible for the dealer to modify the backrest angle.



5.7 Back angle (with angle adjustable back)

- Pull the release rope with one hand as shown and move the back construction backwards with the other hand.



- Engage both bolts audibly in the desired back angle position.



5.8 Active degree

The active degree describes the relation of the backrest position to the rear wheels. The more the backrest is positioned to the rear of the axle, the more active the **SUPRA 2.0** can be driven. That means contrary a safer driving position if the adjustment is set above or in front of the rear axle.



CAUTION!
Push sharply on each rear wheel to ensure that the quickrelease axles are securely located.



5.9 Anti-tip

- The angle of the anti-tippers can be adjusted infinitely variable by loosening the screws.



The anti-tip should be adjusted that it is 2-3 cm above the ground.



Press the snap button and choose the desired length position. The length of the anti-tipper tubes can be adjusted in the anti-tipper bracket in three positions 2.5 cm apart.



5.10 Detaching the rear wheels with quick-release axles

The rear wheels are removed by means of a quick-release mechanism. This reduces the volume of the wheelchair for transportation.

- Grip the spokes close to the wheel hub and, with the thumb, press the release knob of the quick-release axle.
- Pull the rear wheel with the quick-release axle out of the axle housing.
- To avoid a risk of snagging, it may be preferable to withdraw the quick-release axles from the rear wheels.
- To re-assemble the rear wheels refer to section: „4 Delivery and preparing for use“.



CAUTION!

Push sharply on each rear wheel to ensure that the quickrelease axles are securely located.



5.11 Pneumatic tires / PU-tires

The rear wheels can be supplied with pneumatic tires (left). The car type valves enable the tyres to be checked or inflated at any petrol station or by means of a suitable pump, supplying a minimum 6 bar pressure.

Check the maximum tire pressure, which is indicated on the tire.



Wheels with pneumatic tires are equipped with hoses. They can be repaired with repair materials available from the bicycle shop.



The drive wheels can also be supplied with solid PU-tyres.



5.12 Push rims

Push rims can be supplied in aluminium or stainless steel according to preference.



Push rims can be supplied with a standard diameter or with a larger diameter.

These are called respectively hand rims “standard” or push rims “high”.

The **SUPRA 2.0** wheelchair was built in accordance with the customer’s order. It is possible for the retailer to fit alternative push rims.



All push rims can be mounted close to the rear wheel or a little further apart. A future modification is possible again.



6 Accessories

All accessories not installed by the manufacturer must be installed by trained technicians.

The following notes on installation are for your information but should be performed by trained technicians.



6.1 Lower leg length

SUPRA 2.0 was built in accordance with the customer’s order.

After releasing and removing both screws as shown it is possible to adjust the required lower leg length continuously.

- Retighten both screws securely.



Whenever you change any settings on the wheelchair, make sure that you firmly tighten any screws that have been loosened.

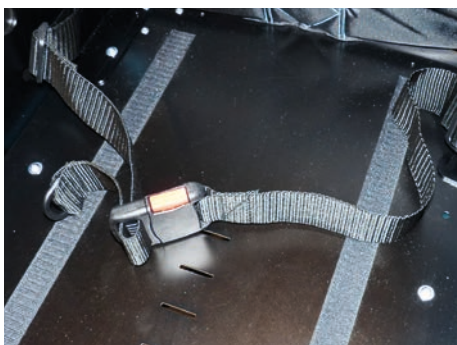

6.2 Lapbelt

The lap belt can be ordered as an option for the **SUPRA 2.0**. It is supplied with buckles, which are attached to the seat plate.

The length of the free belt end causes the lap belt length. The lap belt opens by pressing the red button. It can be retightened at the belt buckle by pulling the belt end (fine adjustment).



7 Transportation

7.1 In the trunk

Depending on its size and features, **SUPRA 2.0** can be transported in one piece.

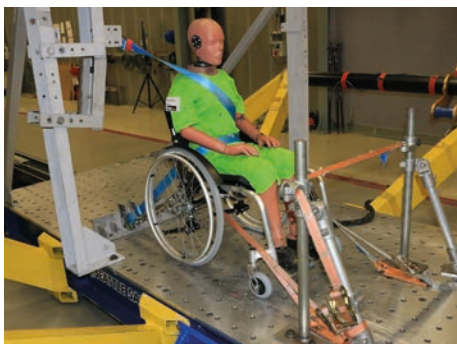

7.2 Use of your wheelchair for transport in disabled transport vehicles

CAUTION!!

We recommend that, wherever and whenever possible, users transfer to the seats installed in the motor vehicle and use the corresponding vehicle restraint systems, because this is the only way to ensure optimum protection of the passengers in case of an accident.

SUPRA 2.0 is admitted for use as a seat in a motor vehicle.

Always make sure that the tractive force per belt (max. 10 kg) must not be exceeded when transporting in the bus, otherwise the frame of the wheelchair could be damaged.

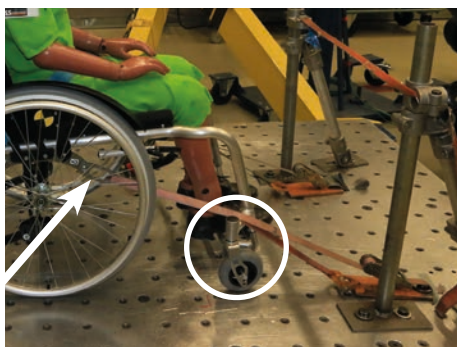

7.3 General

- Check that your wheelchair is suitable for a crash test.
- Check that the vehicle is equipped and compatible for transporting your wheelchair.
- Pay attention to the correct course of the belt (see marking)
- There should also be enough space for safe transport.
- During transport ensure an upright sitting position.



Please note that improper use of a wheelchair in a wheeled ambulance can be dangerous beyond typical use.

Failure to follow this advice will result in serious injury or death.

7.4 Securing the wheelchair during bus transport



We recommend that, wherever and whenever possible users transfer to the seats installed in the motor vehicle and use the corresponding vehicle restraint systems, because this is the only way to ensure optimum protection of the passengers in case of an accident.

SUPRA 2.0 was successfully tested in accordance with ISO 7176-19 (Crash Test).

It is, however, possible to use **SUPRA 2.0** as a seat in a motor vehicle, if our "Tie down Kit" as well as appropriate restraint systems are used. Your **SUPRA 2.0** is admitted for use as a seat in a motor vehicle yet.

1) If the user finds itself in the rehab pushchair, the rehab pushchair has to be positioned forward and has to be fixed

with the fastening and safety belts according to the instruction for use of the restraint system manufacturer

(fastening belts referred to WTORS need to fulfil the requirements of ISO 10542 or SAE J2249).

2) The wheelchair has not been tested for transportation in another position. The transportation in a lateral directed position for instance is not allowed at all.

3) Depending on the size of the pushchair the maneuverability can be impaired, so that the turning of the pushchair

is not or only partially possible, to position the stroller forward in the direction of travel.

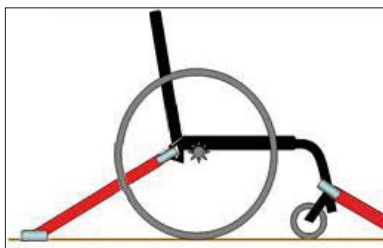

4) The buggy has to be fixed with a restraint system referred to ISO 10542 or SAE J2249 with fixed belts in the front and adjustable belts in the back.

Usually this concerns snap hooks/ s-shaped hooks as well as plug closures. The restraint systems usually consist

of 4 single belts, which have to be attached to the 4 edges of the pushchair. The attachment points of the pushchair

restraint systems are marked with the international hook symbol.

5) The wheelchair may also be supplemented for transport with other positioning and fixation systems. However,

these are not a substitute for passenger and rehab pushchair restraint systems and may limit user comfort.

The accommodation of a wheelchair in a vehicle using anchored belts was rated as „poor“ according to the test

methods of ISO 7176-19 Appendix D.



SUPRA 2.0 may only be used forward in the direction of travel.



The wheelchair was dynamically tested in the direction of travel and the dummy was there fastened with lap belt and shoulder strap.



In order to reduce the risk of injury to vehicle occupants, tools that are not specifically designed for crash safety, should be removed and stored separately in the vehicle safely such. eg crutches, loose pillows, therapy tables etc.



Without consulting the manufacturer, no changes may be made or replaced at the points of attachment of the wheelchair or to components of the chassis and frame. Failure to comply with these requirements, the wheelchair may not be transported in vehicles..

7.5 Buckling the wheelchair passenger

The user has to be buckled up with the lap belt as well as the shoulder belt.

Shoulder and lap belts should be used to minimize and / or avoid potential injury from impact on vehicle components.

- 1) The person executing the attachment should be trained in the handling of the system.
- 2) Before transportation the following adjustments of the rehab buggy have to be carried out:
 - Seat: 0° - 5°
 - Backrest: 90° - 100°
 - Footrest: 90°
- 3) The angle between lap belt and horizontal has to be 30° - 75° . An angle close to 75° is preferable.

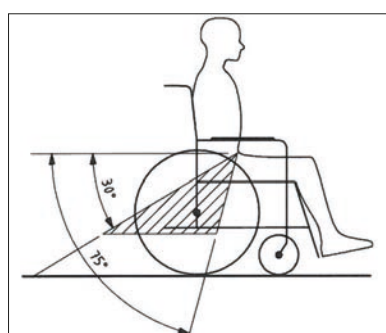
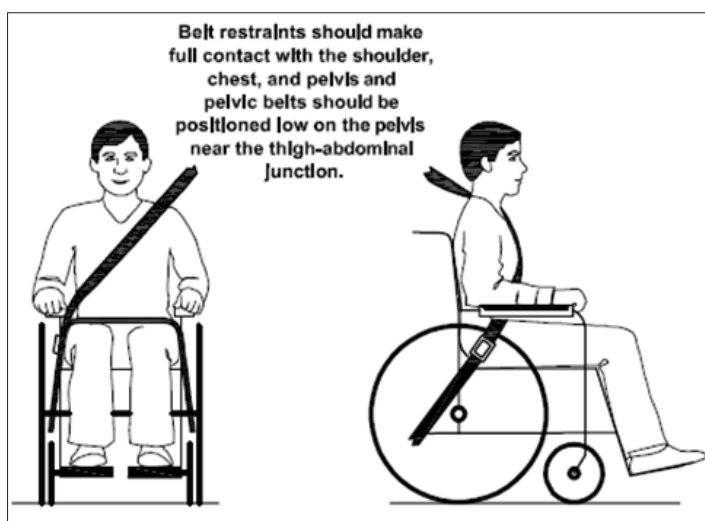

4) The shoulder belt has to run across to chest and shoulder. The belt may not but at the neck and may not be attached loose from the shoulder.



The lap belt and the shoulder belt must be flat and as tight as possible against the body and must not be damaged by components such as e.g. Armrests or wheels are kept away from the body and must not restrict user comfort.

5) The belt strap may not be twisted.



As far as possible all additives should be detached and stored securely:
• crutches, loose cushions and therapy trays.

6) The user's head should be additionally secured by a separate and permanently mounted headrest in the bus.



You should not rely on the occupant restraint systems unless they are marked in accordance with the requirements of ISO 7176-19: 2008.

7) During transport, the drum brake must not be tightened.

8) Please lock the manual brake firmly.



Care should be taken that the occupant restraint is positioned so that in the event of an accident, the release button is not triggered by pushchair components and results in unintentional opening of the seat belts.

9) Remember, however: In the event of a traffic accident, the risk of injury can only be minimized and not ruled out, even if the passenger and rehab pushchair restraint systems are used correctly.



Before reusing the pushchair after a collision or an accident with a bus, the pushchair may no longer be used for transport in a bus until it has been checked for possible damage by authorized personnel and then released again.

If you have questions about our products and transport safety devices for wheelchairs, we or your specialist dealer will be happy to help.



Attachment points, front according to ISO 7176-19



Attachment points, rear according to ISO 7176-19 for lap belt



Attachment points, rear according to ISO 7176-19



7.6 Transfer getting into or out of the wheelchair



ATTENTION!

- Always lock the wheel locks before getting into or out of the wheelchair.
- First practise boarding the chair with the child and an attendant who can secure the wheelchair, and modify footplate and seat height settings if the chair has a tendency to tip over.
- Increase the safety against tipping by turning the steering wheel fork forwards (this increases the wheelbase).



For adolescents it can be advantageous, according to age, weight and ability, to make a transfer over the side of the wheelchair.

- Firstly position the wheelchair at an angle of 45° to the seat or wheelchair, from which a transfer is to be made.
- Lock the brakes.

For support during the transfer please use the seat / back surface, hand rims and for a short time also the side parts.

The transfer should be practiced with an auxiliary person until it is safe succeed. The move should be done in one go.

Then fold down the foot board and position your feet on the foot board. If necessary, correct the seating position. Finally, the parking brakes can be released and the wheelchair can be used.

To exit, proceed in reverse order.



7.7 Anti-tippers to override steps

SUPRA 2.0 can be equipped with an anti-tip unit. Anti-tippers increase the safety of the wheelchair against tipping.

Function and attachment of the footrest lock are described in „4 Delivery and preparing for use“ and „5.9 Anti-tip“.



CAUTION!

If the overriding of steps are only with the help of another person possible - a mounted or active anti-tip can lead to falls.

Adjust the anti-tip so that it can not touch the steps.

After overriding the steps or similar barriers adjust the anti-tip again.



8 Storage

Depending on its size and features, **SUPRA 2.0** can be folded in one piece with the backrest folded in and the footrest folded up to be stored.



Care instructions!

Clean **SUPRA 2.0** thoroughly before storage.

Please observe the care instructions on page 27.



However, there is also the possibility to disassemble the wheelchair with a few simple steps into a few smaller packages.

The smallest size can be achieved by folding in the backrest and footrest and removing the rear wheels.



Care instructions!

Clean **SUPRA 2.0** thoroughly after storage.

Please observe the care instructions on page 27.

9 Recycling and disposal

SUPRA 2.0 is made from recyclable materials.

The product packaging as well as all metal, aluminum and plastic parts can be recycled.

Disposal must be carried out in accordance with the respective national, statutory regulations.

Please ask the city / municipal administration for local ones waste disposal company.

10 Maintenance / Service and Repairs and operating life

Your **SUPRA 2.0** is CE approved. The manufacturer herewith guarantees that this medical product as a whole conforms to the basic safety and performance requirements in accordance with Annex I to Regulation (EU) 2017/745 of the EU Parliament and of the Council. The wheelchair should be checked for correct function before every use. Nuts with self-assurance should only be used once. After repeated loosening nuts must be replaced. The items listed in the following table must be checked by the user at the indicated intervals.

Check	daily	weekly	monthly
Function test of the brake/wheel lock	X		
Function test of the anti-tip	X		
Fixed seat of the drive wheels (quick-release axle)	X		
Check firmness of the footrest		X	
Air pressure (indicated on the side wall of the tyre)		X	
Gripping ring for damage		X	
Testing the screw connections		X	
Visual inspection of wearing parts such as wheels and bearings			X
Contamination on bearings			X
Checking the spoke tension of the drive wheel		X	

Should any defects become obvious, please contact your authorized **HOGGI** dealer to eliminate them. We also recommend that you have your **SUPRA 2.0** serviced by your technician every twelve months.

Instructions for cleaning and maintenance

- Clean all frame components and plastic parts using mild detergents only. (e.g. Sagrotan).
- Padding parts can be washed at 40 °C. If washed in a washing machine, put them in a linen bag or a pillow case.
- In most cases, wiping with a damp cloth is sufficient.
- Do not use your **SUPRA 2.0** in salt water.
- Keep sand or other particles from damaging the wheel bearings.
- If your **SUPRA 2.0** gets wet, towel-dry it as soon as possible.
- Hair and dirt particles generally accumulate between the caster wheel and fork. This can restrict the caster wheels from rotating smoothly. Remove the caster and thoroughly clean the fork and caster using a mild detergent.
- The rear wheels feature a quick-release system. To keep this system operational, ensure that no dirt adheres to the quick-release axle or axle housing. The quick-release axle should also be lightly lubricated regularly with resin-free sewing machine oil.
- Screw connections should be checked frequently, in particular when beginning to use the wheelchair and after any adjustment. If a screw connection becomes loose repeatedly, consult your dealer.



SUPRA 2.0 life cycle:

The expected life cycle of **SUPRA 2.0** amounts to 6 years, dependent on use intensity and maintenance. We recommend a yearly check by your authorized dealer. In case of any disorders or defects it's intended to hand over the wheelchair the health care supply store or your authorized dealer.

	Size 1	Size 2	Size 3
Seat width SUPRA 2.0	300 - 340 mm	300 - 380 mm	300 - 440 mm
Seat width SUPRA 2.0 Abdu	240 - 340 mm	280 - 380 mm	280 - 380 mm
Seat depth	230 - 390 mm	240 - 440 mm	290 - 490 mm
Backrest height	200, 250, 300, 350 mm	200, 250, 300, 350 mm	200, 250, 300, 350 mm
Seat height* (front)	360 - 450 mm	380 - 470 mm	430 - 510 mm
Seat angle	ca. 0° up to 10°	ca. 0° up to 10°	ca. 0° up to 10°
Back angle (rigid back)	70° - 115°	70° - 115°	70° - 115°
Back angle (Back with relief position)	70° - 115° (+15°)	70° - 115° (+15°)	70° - 115° (+15°)
Lower leg length	160 - 400 mm	190 - 410 mm	230 - 460 mm
Footrest angle	adjustable ca. +/- 10°	adjustable ca. +/- 10°	adjustable ca. +/- 10°
Rear wheel diameter	20" (508 mm), 22" (559 mm)	20" (508 mm), 22" (559 mm), 24" (610 mm)	22" (559 mm), 24" (610 mm)
Wheel diameter	100, 125, 140 mm	100, 125, 140 mm	100, 125, 140 mm
Camber	3°, 6°, 9°	3°, 6°, 9°	3°, 6°, 9°
Load capacity**	60 kg	75 kg	100 kg
Weight ***	9,3 kg	9,9 kg	10,5 kg
Overall length maximal / minimal	750 mm / 600 mm	830 mm / 660 mm	910 mm / 720 mm
Overall width maximal / minimal	620 mm / 460 mm	680 mm / 460 mm	700 mm / 470 mm
Height maximal / minimal	670 mm / 530 mm	710 / 540 mm	750 mm / 550 mm
Weight (of the heaviest part)	6,1 kg	6,4 kg	6,8 kg
Static stability (forwards / backwards / to the side)	>10°	>10°	>10°
Maximum slope (for using the parking brakes)	10°	10°	10°
Knee angle	90°	90°	90°
Minimal turning area	1100 mm	1100 mm	1100 mm



ATTENTION!

*The seat height depend on the frame size, the wheel diameter and the camber.



ATTENTION!

**Accessories and mounting parts reduce the remaining vehicle load capacity.



ATTENTION!

*** Weight refer to a **SUPRA 2.0** with basic configuration and maximum seat width.

HOGGI GmbH
Eulerstraße 27 • 56235 Ransbach-Baumbach • Deutschland
Telefon: (+49) 2623 / 92 499-0
E-mail: info@hoggi.de • www.hoggi.de