

---

# HOGGI<sup>®</sup>



## SUPRA 2.0 Service instructions

---

en

---

# SUPRA 2.0 - Service and maintenance instructions

Content	Page
<b>1 Model identification &amp; basic configuration</b>	
1.1 Model identification (label)	4
1.2 Basic configuration	5
1.3 Environmental conditions	5
<b>2 Overview SUPRA 2.0</b>	<b>6</b>
<b>3 Common information</b>	<b>7</b>
3.1 Preface	7
3.2 Application	8
3.3 Declaration of conformity	8
3.4 Terms of warranty	8
3.5 Customer service	8
3.6 Service and repairs	9
3.7 Packing and shipping instructions	9
<b>4 Safety Instructions</b>	<b>10</b>
4.1 Meaning of symbols	10
4.2 Common safety instructions	10
<b>5 Required tools and maintenance schedule</b>	<b>11</b>
5.1 Required tools	11
5.2 Maintenance schedule	12-13
<b>6 6 Seat settings</b>	<b>14</b>
6.1 Seat height and Seat angle	14
6.2 Seat depth	14-15
6.3 Active degree	15-19
6.4 Back height	20
6.5 Back angle adjustment	21
6.6 Lower leg length	22
6.7 Footrest angle and depth	22
6.8 Armrest height	23
6.9 Wheel fork adjustment	24
<b>7 Maintenance schedule</b>	<b>25</b>
7.1 Frame and seat unit	25
7.2 Back section and latching unit	25
7.3 Bearing plate and axle mount	25
7.4 Axle tube	26
7.5 Braking system	27-28
7.6 Wheel fork holder	28-29
7.7 Front wheels	29
7.8 Rear wheels	29
7.9 Push rims	29

---

7.10	Push bar and handles, One hand push-handle	30
7.12	Tie down kit	31
7.13	Back extension	31
7.14	Footrest bracket	31-32
7.15	Clothes guard & fender	32-33
7.16	Therapy tray	33
7.17	Spoke guards	33
7.18	Calf strap	33
7.19	Anti tip and tip assist	34
7.15	Abduction block	34
7.16	Seat and back cushion	34
7.17	Headrest	35
7.18	Back cover & edge protection	35
7.19	Belt fixations	36
<b>8</b>	<b>Operating life</b>	<b>37</b>
<b>9</b>	<b>Specifications</b>	<b>37</b>

# 1 Model identification

## 1.1 Model identification (label)

(The label is attached to the axle tube)

The image shows three identical labels for a HOGGI SUPRA 2.0 Gr. X axle tube. Each label contains the following information:

- Colour code:** MD
- Article number:** 3281-00SB-XXX
- Size:** Gr. X
- Serial number:** 202105003 2021178999
- CE label:** CE XXXkg
- Classification / Product name:** HOGGI SUPRA 2.0
- Date of manufacture:** 202105003
- Maximum load / load capacity:** XXXkg
- Manufacturer:** HOGGI GmbH
- Place of manufacture:** 56235 Ransbach-Baumbach
- Year of manufacture:** 2021
- UDI Code:** (01) 20404734600000221 202178999

Labels on the right side of the image point to these specific fields on the labels.

---

## 1.2 Basic configuration

- Rigid frame active wheelchair in aluminium construction, powder-coated; seat depth grows with the user
- 3 frame sizes:
  - Frame size 1: SW 24-34cm in 2cm-Steps, SD 23-35 cm
  - Frame size 2: SW 28-38cm in 2cm-Steps, SD 24-44 cm
  - Frame size 3: SW 28-38cm in 2cm-Steps, SD 29-49 cm
- HOGGI light rear wheels inclusive push rims (removable via quick-release axle)
- Cloth cover side panels straight
- Camber 6°, 9° or 12°
- Backrest angle: 70° up to 105° adjustable
- adjustable back cover
- Front seat heights: 38 cm up to 51 cm
- Seat angle: 0° bis ca. 10°
- Convertible to other seat widths
- Footrest: Standard
- Load capacity: 60 kg (SW 24-32), 80 kg (SW 34-38), 100 kg (SW 40-44)

## 1.3 Environmental conditions

Environmental factors such as temperature and humidity can damage the wheelchair. The manufacturer recommends not condensing the SUPRA 2.0 at ambient temperatures between -20 ° C and + 40 ° C and a humidity of 5 to 100%.

Caution: Prolonged exposure to the sun may cause parts of the wheelchair to become hot. Be sure to!

---

## 2 SUPRA 2.0 Overview

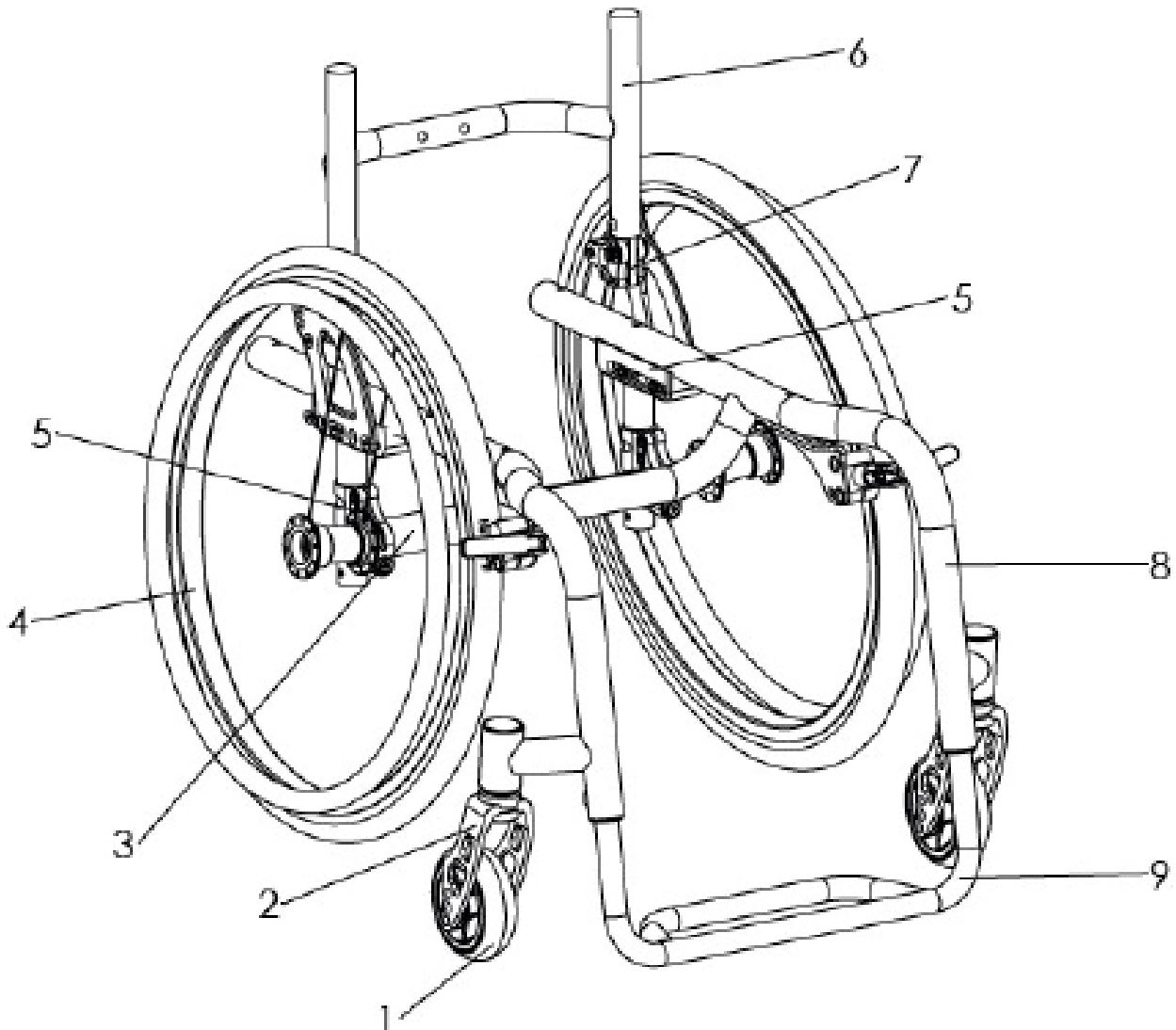

Pos	Article number	Article description
1		Front wheels
2	1281-002x	Wheel fork
3	3210 11SB	Axle tube and adapter housing
4		Tires
5	3281-12SB	Rear axle mounting
6		Back base
7	3201-340x	Mounting parts for back base
8	3218 xxxx	Frame SUPRA 2.0
9	32xx-4xxx	Footrest hanger

---

---

## 3 Common Information

### 3.1 Preface

Thank you for selecting the **SUPRA 2.0** wheelchair. We have designed this high-quality product to make your life safer and easier, and we've included this manual to help you use and care for it. Please read the following instructions to make sure you use this product as recommended. If you have any further questions, or if you have any problems, please contact your healthcare provider.

We hope that **SUPRA 2.0** meets your expectations.

We reserve technical modifications regarding the specified model in this manual. Before using the wheelchair the first time, this manual has to be read and understood by patient and support personnel in order to ensure a safe handling with the wheelchair.

Regular maintenance is important - it increases safety and prolongs the life of the product. Every rehab product should be checked and serviced once a year.

However, it is recommended to check, readjust and, if necessary, service products with a high frequency of use, with users in growth or users with a changing clinical picture at 6-month intervals.

Only original spare parts should be used for all service and maintenance work.

The service and maintenance work described here should only be carried out by trained specialist personnel and not by the user of the aid.

These service and maintenance instructions refer to the respective spare parts catalogs and operating instructions of the products described. Please use all documents together.

Use the maintenance schedule (Chapter 5.2, Checklist to tick off) as a copy template.

Retain completed maintenance schedules and provide a copy to the customer.

---

**SUPRA 2.0**

User manual

1910-0049-EN

---

---

## 3.2 Application

**SUPRA 2.0** wheelchair is designed solely for individual indoor and outdoor use by children and adolescents who are unable to walk or who have a walking impediment, and can be operated by the patient or by another person.

Assistance may be required due to:

- Paralysis (paraplegia / tetraplegia or tetraparesis)
- Loss of limbs (dysmelia/lower limb amputation)
- Infantile/spastic cerebral palsy
- Spina Bifida
- Muscle and nerve disorders
- Osteogenesis Imperfecta
- Poliomyeliti

**SUPRA 2.0** wheelchair is able to be used for further service. For further service the product has to be cleaned and sanitised efficiently. Afterwards the product has to be checked concerning condition, wearout and damage by an authorised technician. All damaged and inapropptiate parts need to be changed. Some components can be used again, e.g. Rear wheels, steering wheels or push handles. Please see also the service manual for detailed information.

## 3.3 Declaration of Conformity

HOGGI GmbH as manufacturer declares under sole responsibility that the **SUPRA 2.0** active wheelchair meets the general safety and performance requirements to Annex I of the Regulation (EU) 2017/745 of the European Parliament and of the Council. Applicable harmonized standards have been applied. **SUPRA 2.0** meets the requirements of ISO 7176-8, DIN EN ISO 12182 and DIN EN ISO 12183.

## 3.4 Terms of Warranty

Warranty applies only when the product is used according to the specified conditions and for the intended purposes, following all manufacturer's recommendations. The manufacturer is not responsible for damages caused by components and spare parts not approved by the manufacturer. See also § 8 of terms and conditions on:

**[www.hoggi.de](http://www.hoggi.de)**

## 3.5 Customer service

Our customer service will be happy to answer any technical questions you may have. Please refer to the last page for contact addresses and telephone numbers.



---

### **3.6 Service and repairs**

Service and repairs on the **SUPRA 2.0** wheelchair may only be carried out by your specialist dealer. In case of problems, contact your responsible specialist dealer. In case of repairs, you will only receive original spare parts there.

Spare parts and replacement units are available during the entire service life of the product, but only for a maximum of 2 years after the sale of the last product in this series.

The wheelchair is custom made for the first time user. Therefore, no replacement wheelchair is available in the initial configuration. In order to ensure a correct spare parts delivery the serial no. of your wheelchair is required.

We are happy to help you find a dealer near you.

You can reach us at: [info@hoggi.de](mailto:info@hoggi.de)

### **3.7 Packing and shipping instructions**

If **SUPRA 2.0** has to be sent back to the manufacturer for repair or exchange the product must be thoroughly cleaned/disinfected beforehand and put in a hygienically safe condition.

Packaging is done by wrapping the product in a clean film, ideally with air cushions and the subsequent use of a sufficiently large cardboard box, so that no transport damage can occur.

---

## 4 Safety instructions

### 4.1 Meaning of symbols



Caution!  
Warning of possible danger of accident and injury. Warning of possible technical damage.



Information!  
About use of product.



Information!  
For service-personnel.



Attention!  
Read manual before use!

### 4.2 Common safety instructions

For all maintenance and repair work, you should generally observe a few points:



Attention!  
Familiarize yourself with the functions of the product. If you are not familiar with the product, study the user manual before testing. If no user manuals are available, request them from us. You can also download documents from our homepage at: [www.hoggi.de](http://www.hoggi.de)



Attention!  
Study the service and maintenance instructions before starting work.



Attention!  
Use suitable tools (see page 4 ff.).



Attention!  
Wear suitable clothing and, if necessary, gloves and protective goggles.



Attention!  
Secure the product from tipping over or falling down, e.g. from the workbench.



Attention!  
Clean / disinfect the product before starting the test. If necessary, observe the instructions in the user manual and product-specific test instructions.



Note!  
Screws and nuts with thread locking are used for a large number of screw connections. If you have to open such screw connections, replace the respective nut or screw with one with new thread locking. If new nuts or bolts with thread locking are not available, use liquid thread locking compound with medium strength (e.g. Loctite 241 or Euro Lock A24.20).

---

## 5 Required tools and maintenance schedule

### 5.1 Required tools

The following list shows the tools and utilities required for service.



Reversible ratchet and sockets  
size 8-24



Torque wrench  
Measuring ranges 5-50 Nm



Wrench  
Size 6 - 24



Hexagon wrench  
Gr. 3 - 6



Screwdriver  
Blade width 2.5 3.5 and 5.5



Phillips screwdriver  
Size 2



Plastic hammer



Hammer approx. 300 g



Carpet knife with sickle and  
standard blade



Side cutter



Liquid thread locking  
„medium strength



Riveting pliers for rivets up to  
5 mm

Maintenance schedule for regular inspection		<b>SUPRA 2.0</b> Active wheelchair		Customer: .....	
Pos.	Area	Check (Checklist to tick off <input checked="" type="checkbox"/> )			
	Serial number: .....	1.) Function / Setting (see instruction manual)	2.) none damage / deformation	3.) Screw connections	
1. Basic product					
1.1	Frame and seat unit	- Damages	<input type="checkbox"/>	<input type="checkbox"/>	<input type="checkbox"/>
1.2	Back section and latching unit	- Backrest angle	<input type="checkbox"/>	<input type="checkbox"/>	<input type="checkbox"/>
		- Backrest height	<input type="checkbox"/>		<input type="checkbox"/>
1.3	Bearing plate and axle mount	- Seat depth	<input type="checkbox"/>	<input type="checkbox"/>	<input type="checkbox"/>
		- Active degree	<input type="checkbox"/>	<input type="checkbox"/>	<input type="checkbox"/>
1.4	Axle tube	- Seat height	<input type="checkbox"/>	<input type="checkbox"/>	<input type="checkbox"/>
		- Seat angle	<input type="checkbox"/>	<input type="checkbox"/>	<input type="checkbox"/>
		- Camber	<input type="checkbox"/>	<input type="checkbox"/>	<input type="checkbox"/>
1.5	Braking system	- Brakes	<input type="checkbox"/>	<input type="checkbox"/>	<input type="checkbox"/>
1.6	Wheel fork holder	- Swivelling the wheel forks	<input type="checkbox"/>	<input type="checkbox"/>	<input type="checkbox"/>
1.7	Front wheels	- Tires	<input type="checkbox"/>	<input type="checkbox"/>	<input type="checkbox"/>
		- Air pressure	<input type="checkbox"/>		
		- Running behavior of the wheels	<input type="checkbox"/>		
1.8	Rear wheels	- Tires	<input type="checkbox"/>	<input type="checkbox"/>	<input type="checkbox"/>
		- Air pressure	<input type="checkbox"/>		
		- Running behavior of the wheels	<input type="checkbox"/>		
		- Quick release	<input type="checkbox"/>	<input type="checkbox"/>	
1.9	Push rim	- Mounting position	<input type="checkbox"/>	<input type="checkbox"/>	<input type="checkbox"/>
		- Cover	<input type="checkbox"/>	<input type="checkbox"/>	
	Do the settings on the wheelchair meet the user's requirements?		<input type="checkbox"/>		
Notes:					

		1.) Function / Setting (see instruction manual)	2.) none damage / defor- mation	3.) Screw connections
2. Accessories				
2.1	Push bar / push handles One hand push handle	- Höhenverstellung - Winkelverstellung Griffhalter - Abnehmen	<input type="checkbox"/> <input type="checkbox"/> <input type="checkbox"/>	<input type="checkbox"/> <input type="checkbox"/> <input type="checkbox"/>
2.2	Tie down kit	- Bracket	<input type="checkbox"/>	<input type="checkbox"/>
2.3	Back rest extension	- Height adjustment - Cushion	<input type="checkbox"/> <input type="checkbox"/>	<input type="checkbox"/> <input type="checkbox"/>
2.4	Footrest hanger & footrest	- Lower leg length - Folding away the footrest - Angle adjustment	<input type="checkbox"/> <input type="checkbox"/> <input type="checkbox"/>	<input type="checkbox"/> <input type="checkbox"/> <input type="checkbox"/>
2.5	Clothe cover & wheel covers	- Removal - Height adjustment - Cushion	<input type="checkbox"/> <input type="checkbox"/> <input type="checkbox"/>	<input type="checkbox"/> <input type="checkbox"/> <input type="checkbox"/>
2.6	Therapy tray	- Clamping unit	<input type="checkbox"/>	<input type="checkbox"/>
2.7	Spoke guard	- Spoke guard	<input type="checkbox"/>	<input type="checkbox"/>
2.8	Calf strap	- Tension and hold	<input type="checkbox"/>	<input type="checkbox"/>
2.9	Anti tip and tip assist	- Anti tip - Swivel away - Angle adjustment	<input type="checkbox"/> <input type="checkbox"/> <input type="checkbox"/>	<input type="checkbox"/> <input type="checkbox"/> <input type="checkbox"/>
2.10	Abduction block	- Bracket - Swivel mechanism	<input type="checkbox"/> <input type="checkbox"/>	<input type="checkbox"/> <input type="checkbox"/>
2.11	Seat / back cushion	- Cushion	<input type="checkbox"/>	<input type="checkbox"/>
2.12	Headrests	- Removal - Height adjustment - Angle adjustment - Cushion	<input type="checkbox"/> <input type="checkbox"/> <input type="checkbox"/> <input type="checkbox"/>	<input type="checkbox"/> <input type="checkbox"/> <input type="checkbox"/> <input type="checkbox"/>
2.13	Back cover & edge protection	- Pads - Velcro	<input type="checkbox"/> <input type="checkbox"/>	<input type="checkbox"/> <input type="checkbox"/>
2.14	Belt fixings: Lap belt, 4-point lap belt, ankle hugger	- Closures	<input type="checkbox"/>	<input type="checkbox"/>
Notes:				
The maintenance was performed by:..... on:.....				

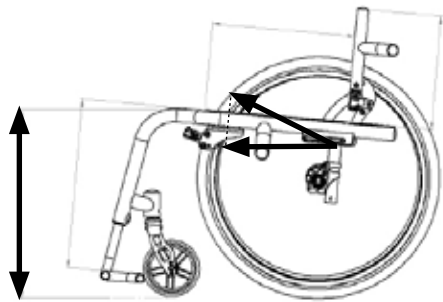

## 6. Seat settings

### 6.1 Seat height & seat angle

The seat height and angle of the SUPRA 2.0 can be adjusted via different steering wheel and caster fork sizes and by moving the drive wheel axle in relation to the rear wheel axle mount.

Seat height: 38 - 51 cm

Seat angle: 0° - 10°

SUPRA 2.0 Seat height front																			
Frame size	Seat angle	short front fork, castors pos. 1281-1023									long front fork, castors pos. 1281-1026								
		100			125			140			100			125			140		
		1	2	3	1	2	3	1	2	3	2	3	4	2	3	4	2	3	4
1	0°	38	39	41	39	41	42	40	41	43	41	42	43	42	43	44	43	44	45
	4°	38	39	40	39	40	41	40	41	42	40	41	43	41	43	44	42	43	45
	7°	37	38	39	38	39	41	39	40	41	39	41	42	41	42	43	41	43	44
	10°	36	37	39	37	39	40	38	39	41	39	40	41	40	41	42	41	42	43
2	0°	40	41	43	41	43	44	42	43	45	43	44	45	44	45	46	45	46	47
	4°	40	41	42	41	42	43	42	43	44	42	43	45	43	45	46	44	45	47
	7°	39	40	41	40	41	43	41	42	43	41	43	44	43	44	45	43	45	46
	10°	38	39	41	39	41	42	40	41	43	41	42	43	42	43	44	43	44	45
3	0°	45	46	48	46	48	49	47	48	50	48	49	50	49	50	51	50	51	52
	4°	44	46	47	46	47	48	46	48	49	47	48	49	48	49	51	49	50	51
	7°	44	45	46	45	46	47	46	47	48	46	47	49	47	49	50	48	49	51
	10°	43	44	45	44	45	47	45	46	47	45	47	48	47	48	49	47	49	50

(Measured at front edge of seat cover ± 0,5 cm)

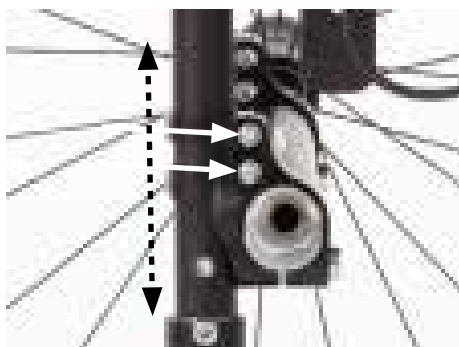

To move the rear wheel axle, the corresponding screws must be loosened.

The axle can then be moved along the axle mountings.

When the desired position is reached, tighten the bolts again.

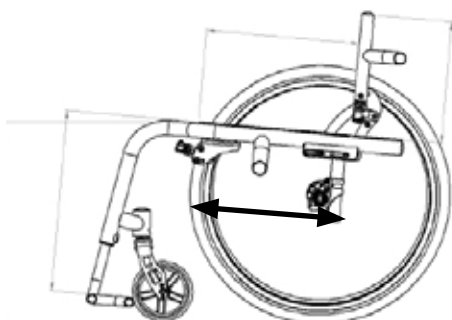

### 6.2 Seat depth

The seat depth of SUPRA 2.0 is realised by shifting the rear axle frame in relation to the seat frame.

Size 1: 23 - 35 cm

Size 2: 24 - 44 cm

Size 3: 29 - 49 cm



After loosening the screw connection of the rear axle frame and the clamping strut in the frame tube, the entire rear axle mount can be moved.

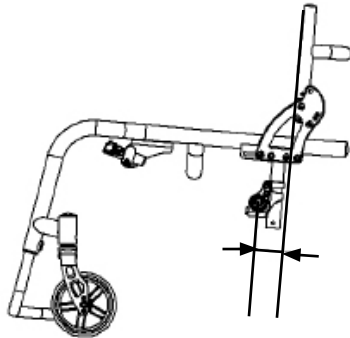

### 6.3 Active degree

The active degree describes the ratio of the position of the backrest relative to the drive wheel axis. The further the backrest is set behind the drive wheel axle, the more active SUPRA 2.0 can be driven. Conversely, a setting above, or in front of, the drive axle means a more stable driving position.

**Caution. Settings with a high degree of activity require an experienced driver and the use of an anti-tippers!**

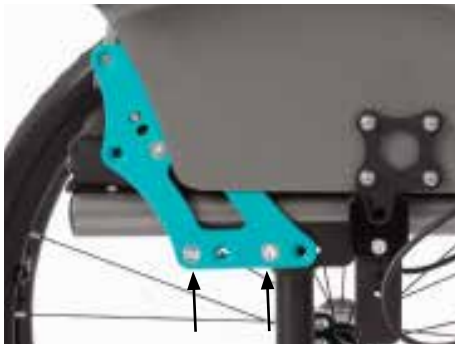

SUPRA 2.0 offers an adjustment range of 0 - 10 cm. For adjustment, the corresponding screw connections of the backrest base to the rear axle mount must be loosened, moved in the slotted holes or moved.

**0 - 3 cm**



Active degree setting 0 - 3 cm and 2 - 5 cm

**2 - 5 cm**

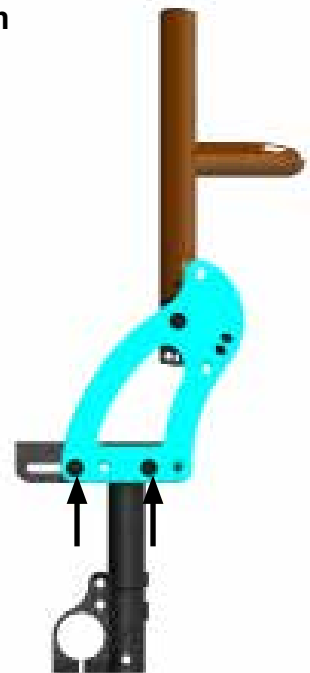

Alignment of the rear axle frame to the front



Active degree setting 5 - 8 cm and 7- 10 cm. **7 - 10 cm**

Alignment of the rear axle frame to the rear

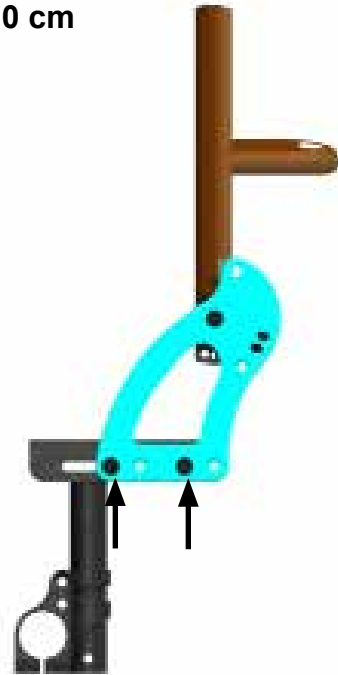

Depending on the seat depth and degree of activity, the 3 frame sizes are as follows:

SUPRA 2.0 Seat depth range												
Wheel size 20"				Wheel size 22"					Wheel size 24"			
AD	Frame size			AD	Frame size			AD	Frame size			
	Gr.1	Gr.2	Gr.3		Gr.2	Gr.3	Gr.2		Gr.3			
0	19-34	20-39		0	21-34	20-39	25-44	0	23-39	25-44		
1	20-34	21-39		1	22-34	21-39	26-44	1	24-39	26-44		
2	21-34	22-39		2	23-34	22-39	27-44	2	25-39	27-44		
3	22-34	23-39		3	24-34	23-39	28-44	3	26-39	28-44		
4	23-34	24-39		4	25-34	24-39	29-44	4	27-39	29-44		
5	24-34	25-39		5	26-34	25-39	30-44	5	28-39	30-44		
6	25-34	26-39		6	27-34	26-39	31-44	6	29-39	31-44		
7	26-34	27-39		7	28-34	27-39	32-44	7	30-39	32-44		
8	27-34	28-39		8	29-34	28-39	33-44	8	31-39	33-44		
9	28-34	29-39		9	30-34	29-39	34-44	9	32-39	34-44		
10	29-34	30-39		10	31-34	30-39	35-44	10	33-39	35-44		



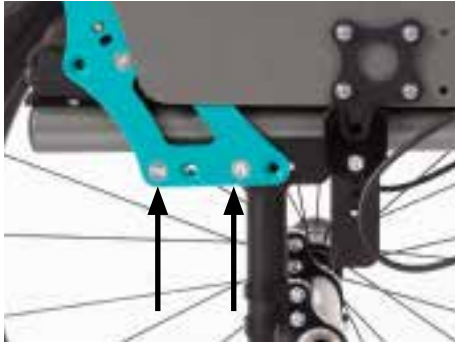

## Conversion rear axle frame

If a change from  $\leq 5\text{cm}$  to  $\geq 5\text{cm}$  is made when setting the active degree to  $\geq 5\text{cm}$ , the rear axle mount must be converted and aligned with the long end to the front.

The first step is to remove the two screws to the bearing plate on both sides, so that the complete back base can be removed.



The screw connections from the rear axle mount to the upper frame must now be loosened and removed on both sides.



Loosen the screw connections from the axle mount to the rear axle frame.



A rear axle frame can now be pulled out of the clamp



Replace the axle frame in the new orientation and rotate the axle by  $180^\circ$ .



Loosen the screw connection to the axle mount and remove the screws completely. Then remove the camber adapters and pull the axle out of the holder.



On the opposite side, also align the rear axle frame in the new position and screw it in place.



Put the clamp back on the rear axle frame with the alignment to the front.



Insert the axle and screw the camber adapters tight again. The exact alignment towards the ground must be checked with a spirit level.

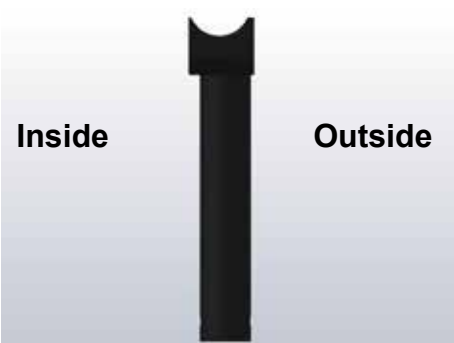

**Important, regardless of whether the alignment is to the front or rear, the rear axle frame must always be mounted as shown with the narrow side facing outwards!**

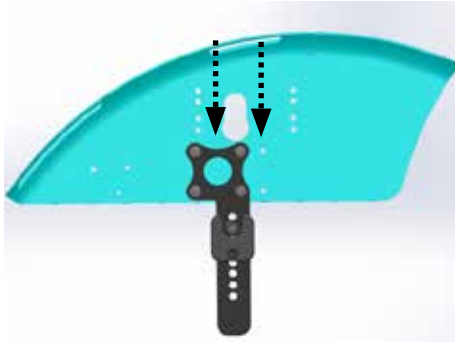

Depending on how the seat depth or the degree of activity has been changed, readjustment of the brakes and/or the wheel covers is necessary.

The side parts can be screwed in 4 positions with the locking sword. This means that the cover can always be aligned centrally over the wheel.

Position 1 and 2

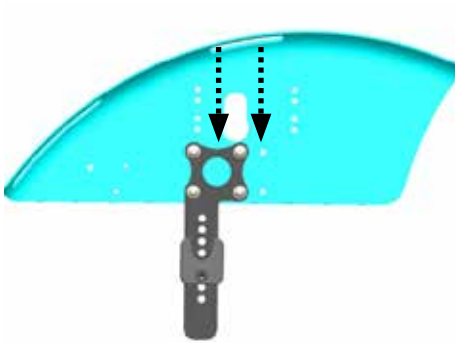

Position 3 and 4



## 6.4 Back height

SUPRA 2.0 is equipped either with an adaptable backrest covering or with a back plate.

The basic backrest heights are 20/25/30/35 cm.

Adjustable backrest covering

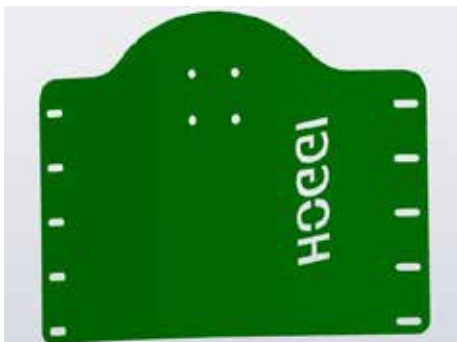

Back panel



The fastening is done via clamps to the back frame.

By loosening the screw connections, the height of the back plate can be adjusted.

A different backrest height can also be achieved by moving the screws into other slotted holes.

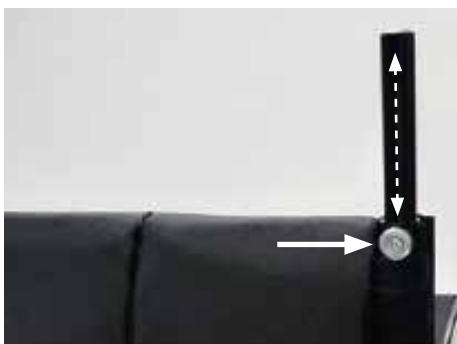

To obtain a corresponding adjustment range, telescopic tubes for back height adjustment or single push handles must be additionally equipped. These offer 10 cm length (back height 20 cm only 5 cm possible for constructional reasons.)

This results in the following adjustment range:

- 20 up to 25 cm
- 25 up to 35 cm
- 30 up to 40 cm
- 35 up to 45 cm

Telescopic tubes



Single push handles

Height adjustment by loosening the screw on the back frame.



## 6.5 Backrest angle adjustment

### Back rigid

The rigid back offers an adjustment range of 70° to 115°. By placing the screw from the outside in one of the front two holes in the bearing plate, the desired range can be preset.

Each hole offers an adjustment range of approx. 22.5°.

Middle hole: approx. 70°- 92,5°  
 Front hole: approx. 92,5°- 115°



Via the 5 hole positions of the back base and the spacer, fine adjustment can be made within the 22.5° adjustment range, depending on how the screw is inserted.

The further forward the screw connection, the smaller the back angle.

The backrest frame is always measured in relation to the seat frame. The 90° backrest angle results from the centre-to-centre position.



### Back with relief position and foldable

The back angle can be varied between two positions, the driving position and the the driving position and the relief position (15° difference).

In addition, the back can be folded down and fixed for transport. for transport.

It is released by means of a locking bolt on the back.



Back folded down and fixed.



Unlike the rigid back, the screw connection is made from the inside.

The adjustment range is also 70° to 115°, depending on the hole position in which the screw is inserted.

In addition, a further 15° is achieved with the relief position, i.e. a total of 70° to 130°.

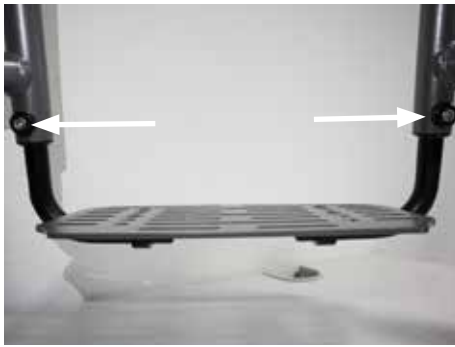

## 6.6 Lower leg length

The lower leg length can be adjusted between 16 and 46 cm depending on the frame size and footrest variant.

The adjustment is made by loosening the screw connection on the frame tube.

**With the variant for short lower leg lengths it may be necessary to shorten the tubes, as otherwise contact with the contact with the floor!**

This results in the following possible combinations:

SUPRA 2.0 Abdu / SUPRA 2.0 Seat height and Lower Leg Length according to frame size								
size	SH (at 90° seat angle)	Footrests						
		3294-475B 3291-475B Tube frame footrest	3294-415B 3291-415B Footrest one piece aluminium footplate, angle adjustable	3294-465B 3291-465B Footrest one piece aluminium footplate, angle adjustable for short LLL reduced by 11 cm	3294-485B 3291-485B Footrest one piece aluminium footplate, angle adjustable for short LLL reduced by 7 cm	3294-435B 3291-435B Footrest one piece aluminium footplate, angle adjustable, foldable	3294-455B 3291-455B Single foot plate footrest, angle adjustable, foldable	3294-405B 3291-405B Footrest one piece aluminium footplate, fold backwards
SUPRA 2.0 Frame size 1	38	28 - 34	28 - 34	16 - 23	20 - 26	28 - 34	28 - 34	28 - 35
	39	28 - 35	28 - 35	16 - 24	20 - 27	28 - 35	28 - 35	28 - 36
	40	28 - 36	28 - 36	16 - 25	20 - 28	28 - 36	28 - 36	28 - 37
	41	28 - 37	28 - 37	16 - 26	20 - 29	28 - 37	28 - 37	28 - 38
	42	28 - 38	28 - 38	16 - 27	20 - 30	28 - 38	28 - 38	28 - 39
	43	28 - 39	28 - 39	16 - 28	20 - 31	28 - 39	28 - 39	28 - 40
	44	28 - 40	28 - 40	16 - 29	20 - 32	28 - 40	28 - 40	28 - 41
SUPRA 2.0 Frame size 2	40	30 - 34	30 - 34	19 - 24	23 - 27	30 - 34	30 - 34	30 - 35
	41	30 - 35	30 - 35	19 - 25	23 - 28	30 - 35	30 - 35	30 - 36
	42	30 - 36	30 - 36	19 - 26	23 - 29	30 - 36	30 - 36	30 - 37
	43	30 - 37	30 - 37	19 - 27	23 - 30	30 - 37	30 - 37	30 - 38
	44	30 - 38	30 - 38	19 - 28	23 - 31	30 - 38	30 - 38	30 - 39
	45	30 - 39	30 - 39	19 - 29	23 - 32	30 - 39	30 - 39	30 - 40
	46	30 - 40	30 - 40	19 - 30	23 - 33	30 - 40	30 - 40	30 - 41
SUPRA 2.0 Frame size 3	44	34 - 40	34 - 40	23 - 28	27 - 32	34 - 40	34 - 40	34 - 41
	45	34 - 41	34 - 41	23 - 29	27 - 33	34 - 41	34 - 41	34 - 42
	46	34 - 42	34 - 42	23 - 30	27 - 34	34 - 42	34 - 42	34 - 43
	47	34 - 43	34 - 43	23 - 31	27 - 35	34 - 43	34 - 43	34 - 44
	48	34 - 44	34 - 44	23 - 32	27 - 36	34 - 44	34 - 44	34 - 45
	49	34 - 45	34 - 45	23 - 33	27 - 37	34 - 45	34 - 45	34 - 46
	50	34 - 46	34 - 46	23 - 34	27 - 38	34 - 46	34 - 46	34 - 47
51	34 - 46	34 - 46	23 - 35	27 - 39	34 - 46	34 - 46	34 - 47	



## 6.7 Footrest angle and depth

Depending on the footrest version, the angle can be adjusted by loosening the front screw.

The depth can be adjusted by repositioning the footrest and using the other holes.



## 6.8 Armrest height

SUPRA 2.0 can either be equipped with clothe cover and PU armrests, or equipped with a wheel cover with armrests. These are always height-adjustable and removable.

Clothe cover with PU armrests.

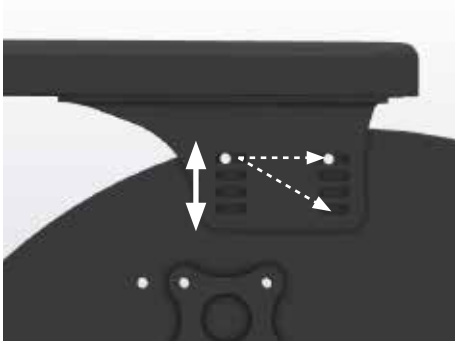

The height is adjusted by moving the armrest in relation to the clothe cover. This results in an adjustment range of approx. 3 cm. The elongated holes can also be used to adjust the angle to compensate for a steep seat angle.

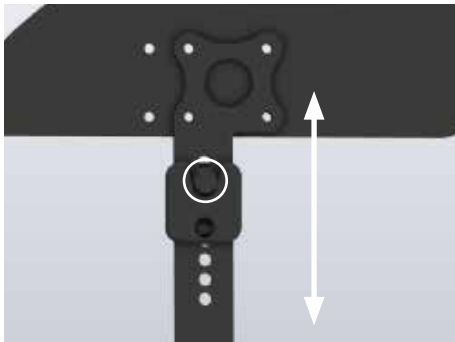

Another adjustment option is the positioning of the insertable sword. Depending on the screw position, the adjustment range is of 7 cm.

In total, the height can be adjusted by 10 cm.

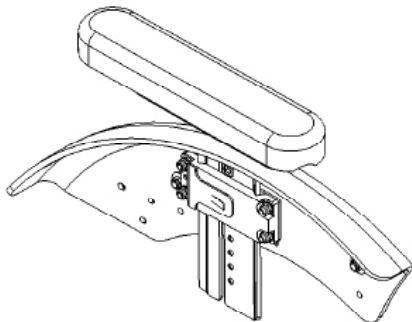

In combination with the wheel cover, there is also an adjustment range of 10 cm.

The wheel cover is released by pressing the push button on the inside. push button.





## 6.9 Wheel fork adjustment

Depending on whether the seat adjustment has been changed, the the alignment of the wheel fork must be adjusted accordingly. To do this, first completely loosen both the upper nut and the side grub screw.

Then slightly tighten the upper screw connection again and align the axle with the help of a spirit level by slightly turning the grub screw clockwise with an Allen key.



If the axle is now aligned straight, the upper screw connection can be tightened firmly with 20 Nm.



Finally, check again with the spirit level and tighten the grub screw again.





## 7. Maintenance schedule

### 7.1 Frame & seat unit

Functional test:

- Check for general damage to frame, seat cover or seat panel
- Screw connections of the seat cover or the seat panel



### 7.2 Back section and latching unit

Functional test:

- Check for general damage (Velcro, sheet metal, telescoping, covers)
- latching pin pull intact with folding backrest
- Correct back angle



Check the screw connections:

- Screwing of the latching unit
- Screwing of the back base
- Telescoping
- Clamps on back plate



### 7.3 Bearing plate and axle mount

Functional test:

- Check for general damage
- correct active degree
- correct seat depth



Check of the screw connections:

- Seat depth adjustment under the axle frame
- Active degree adjustment, screw connection axle frame and bearing plate



## 7.4 Axle tube

Functional test:

- Check for general damage
- Sliding of the axle mount over the frame tube
- Correct seat angle or seat height
- Correct alignment of the camber adapter



Check of the screw connections:

- Two clamping screws on the axle mount
- Front screw connection for fastening the axle tube



## 7.5 Braking system

### Brake HOGGI light

Functional test:

- Brake closure
- Faultless operation
- Visible damage



Brake opened



Brake closed

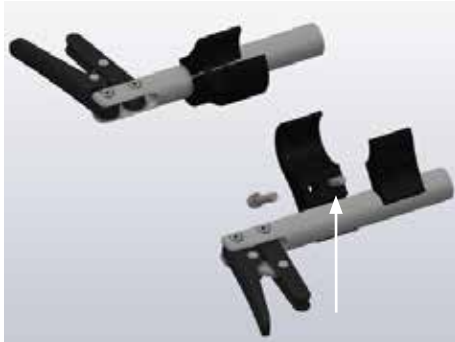

Check of the screw connections:

- Fixing the brake to the brake holder
- Fastening the brake holder to the base plates



### Integrated brake system

Consisting of:

- Fender with integrated brake system
- Brake cable
- Brake

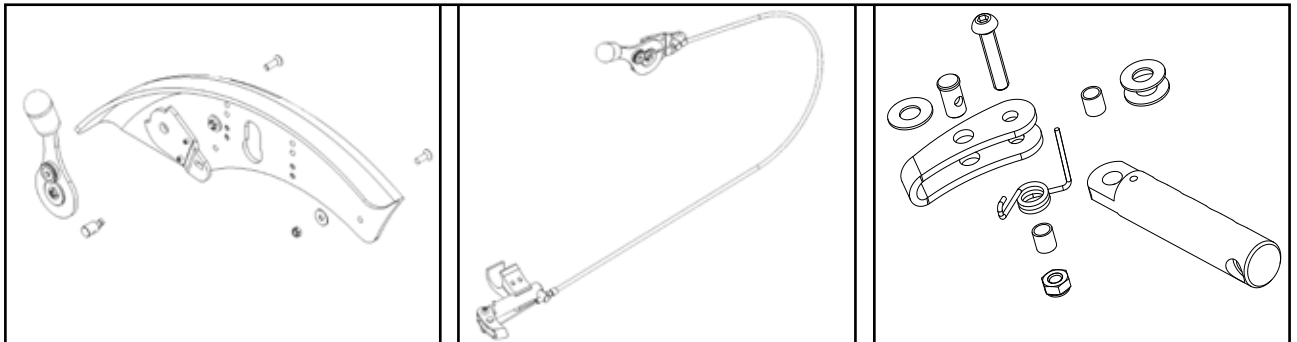

Functional test:

- Operability of the brake lever and smooth glide
- Good brake closure and contact pressure of the brake bracket
- Correct positioning of the brake lever in relation to the wheel. 90° angle and 3-5 mm wheel protrusion
- Check for general damage in the area of the fender and the rubber grip



- Good brake closure and contact pressure of the brake bracket
- Correct positioning of the brake lever in relation to the wheel.
- Check for general damage in the area of the fender and the rubber grip

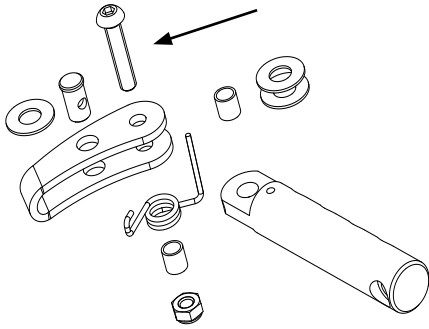

Check of the screw connections:

- Fastening the brake lever in the clamp on the frame

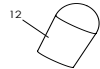

- Fastening the brake bracket to the brake bracket holder
- Bowden cable correctly looped in the cable pulley

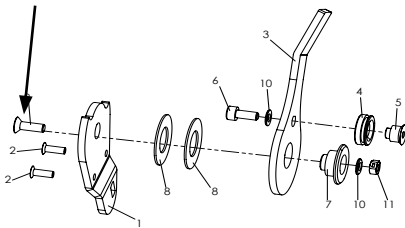

## Drum brake

Functional test:

- Build-up of brake pressure (readjustment at adjusting screw)
- Checking the brake lever for general damage (locking lever, cracks)
- Checking the Bowden cable (kinks or cracks)
- Check the brake anchor and brake pads (contamination, wear)



Check of the screw connections:

- Connection brake anchor with adapter
- Connection of brake anchor adapter with base plate
- Bowden cable correctly hooked in
- Screw connection of the brake handle to the handle unit



## 7.6 Wheel fork holder

Functional test:

- Swivelling of the wheel fork
- Smooth running or fluttering -> Checking the alignment
- Check for general damage to the forks



Check of the screw connections:

- Screw connection of the wheel axle
- Bolting the steering fork axle to the frame



## 7.7 Front wheels

Functional test:

- Check for general damage
- Check of the tread or profile (cracks, heavy wear)
- Wheel curvature too worn (tread max. up to 5mm to edge of wheel)
- Contamination in the area of the wheel bearing or the axle



## 7.8 Rear wheels

Functional test:

- Check for general damage
- Checking the treads and air pressure
- Checking the locking
- Checking the running behaviour of the wheel, clearance, mechanics of the axle
- Checking of the correct alignment of the camber adapter and its bolting



Adjustment of the quick-release axle:

- The axle should be fitted with a minimum of clearance. If too much movement is possible, the front nut is closed slightly clockwise with a 19 mm open-ended spanner in a clockwise direction, while the rear axle is secured with an 11 mm open-ended spanner
- If the wheel is too tight, proceed in reverse order



## 7.9 Push rim

Functional test:

- Check for general damage
- Severe scratching and sharp edges

Checking the screw connections:

- Attachment of handrim to rim, also at correct distance

---

## 7.10 Push bar and handles, One hand push handle

### Push bar

#### Functional test:

- Attachment and removal
- Clamping
- Height adjustment
- Height adjustment of the upper part by means of ratchet joints
- Checking for general damage



### Push handles

#### Functional test:

- Attachment and removal
- Clamping
- Height adjustment
- Straight alignment of the bars
- Checking for general damage



### One hand push handle

#### Functional test:

- Attachment and removal
- Clamping
- Height adjustment
- Checking for general damage



### Height-adjustable single push handles

#### Functional test:

- Check for general damage
- Height adjustment



#### Check of the screw connections:

- Fastening the handle holders to the base plate
- Fastening the cross tube for stabilisation
- Fastening the clamp to the back base



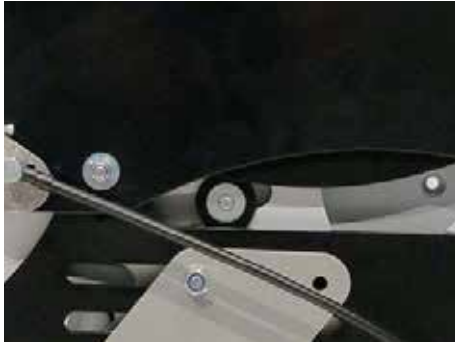

### 7.11 Tie down kit (ISO 7176-19)

Functional test:

- Check for general damage (deformation, sharp edges)

Check of the screw connections:

- Connection of the front and rear fuse to the base plate



### 7.12 Backrest extension

Functional test:

- Check for general damage
- Height adjustment and clamping

Checking the screw connections:

- Connection of the bracket to the back panel



### 7.13 Footrest bracket

#### Tubular stirrup footrest

Functional test:

- Check for general damage
- Height adjustment
- Screw connection to the frame

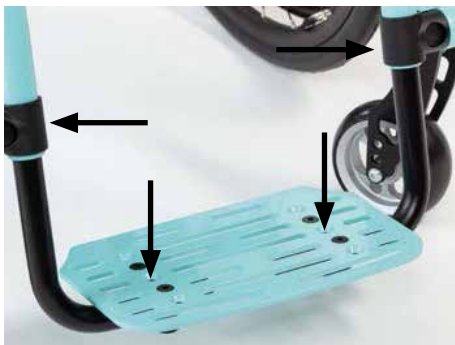

#### Footrest system with continuous aluminium footrest

Functional test:

- Check for general damage
- Height adjustment
- Depth adjustment of the footrest
- Angle adjustment of the footrest
- Screwing of the height adjustment and the footrest bracket



#### Footrest folding back

Functional test:

- Check for general damage
- Height adjustment
- Depth adjustment of footrest
- Folding mechanism
- Screwing of the height adjustment and the footrest bracket

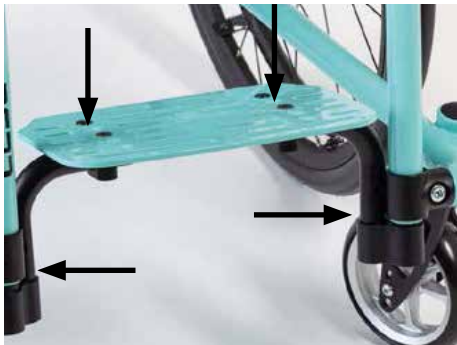

### Footrest hanger for short lower leg length

Functional test:

- Check for general damage
- Height adjustment
- Depth adjustment of the footrest
- Angle adjustment of the footrest
- Screwing of the height adjustment and the footrest bracket

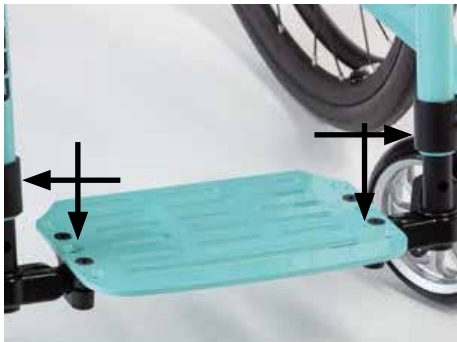

### Footrest hanger folding up

Functional test:

- Check for general damage
- Height adjustment
- Depth adjustment of the footrest
- Angle adjustment of the footrest
- Folding up and swivelling of the footrest
- Screwing of the height adjustment and the footrest bracket

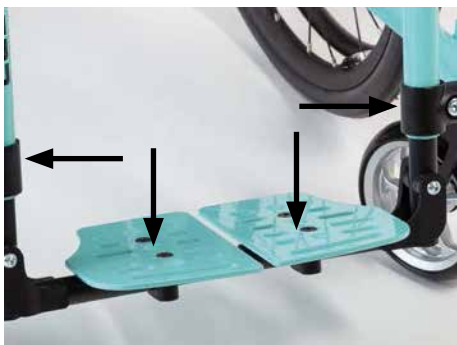

### Single footrests

Functional test:

- Check for general damage
- Height adjustment
- Depth adjustment of the footrests
- Angle adjustment of the footrests
- Swivelling of the footrests
- Screwing of the height adjustment and the footrest brackets



## 7.14 Clothes guard & fender

### Clothes guard (optionally also as variant with armrests)

Functional test:

- Check for general damage
- Height adjustment and removal
- Screwing of the locking screw and the sword
- Screwing of the mounting to the frame



### Standard fender

Functional test:

- Check for general damage
- Screw connection to the base plate firmly tightened



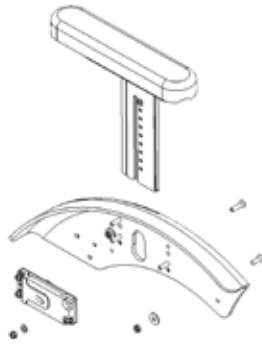

#### Fender with integrated armrests

Function test:

- Height adjustment and latching of the armrest
- Damage to the armrest cushion
- Damage to the release button
- Screw connection to base plate firmly tightened
- Armrest holder firmly screwed to fender

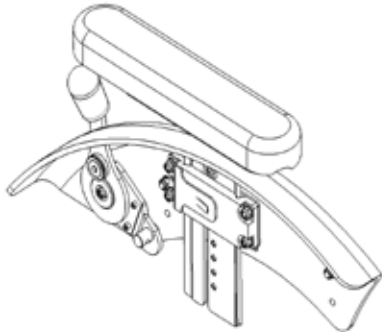

#### Fender with integrated brakes and armrests

Functional test:

- Check for general damage
- Height adjustment and latching of the armrest
- Damage to the armrest cushion
- Damage to the release button
- Checking the brake unit (see 6.4 Brake system)
- Screw connection to base plate firmly tightened
- Armrest holder firmly screwed to fender

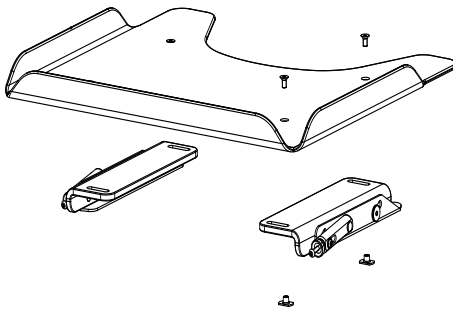

### 7.15 Therapy tray

Functional test:

- Attachability and fixation of the table on the armrests
- Checking for general damage (cracks, sharp edges, etc.)

Checking the screw connections:

- Connection of the table top to the clamping units



### 7.16 Spoke guards

Functional test:

- Check for general damage (cracks)
- Fastening clips complete or defective
- Spoke guards suitable for wheel (drum brake or normal)



### 7.17 Calf strap

Functional test:

- Check for general damage
- Velcro



## 7.18 Anti tip and tip assist

Anti tip

Functional test:

- Check for general damage
- Correct positioning (beyond the wheel radius, 2-3 cm above the floor)
- Checking the swivel mechanism
- Checking the length adjustment



Tip assist

Functional test:

- Check for general damage
- Good grip of the rubber cap



Check of the screw connections:

- Screw connection of the anti tipper or tip assist mounting bracket to the base plate
- Screw connection of the anti tipper or the tip assist to the base plate.e
- Angle adjustment



## 7.19 Abduction block

Functional test:

- Check for general damage
- Pivoting and latching mechanism
- Removal

Check of the screw connections:

- Bracket abduction block to the seat panel



## 7.20 Seat- and back cushion

Standard seat cushion

- Check for general damage (Velcro fastening, seams, holes or strapped-through areas)
- Check for contamination



#### Seat cushion contoured

- Check for general damage (Velcro fastening, seams, holes or strapped-through areas)
- Check for contamination



#### Back cushion

- Check for general damage (Velcro fastening, seams, holes or strapped-through areas)
- Check for contamination



### 7.21 Headrest

#### Headrest bracket

##### Functional test:

- Check for general damage
- Checking the clamping ability
- Checking the screw connection to the back panel



#### Headrest with upholstery

##### Functional test:

- Adjustment possibilities
- Check for general damage (wear, cracks, etc.)
- Clamping ability

##### Checking the screw connections:

- Attachment of pad to support



### 7.22 Back cover & edge protection

##### Functional test:

- Check for general damage
- Velcro straps for hold on the back covering



## 7.23 Belt fixations

Lap belt

Functional test:

- Check for general damage
- Check of the fastener
- Check of the screw connection of the bracket



4-point lap belt

Functional test:

- Check for general damage
- Check of the fastener
- Check of the screw connection of the bracket



Ankle hugger

Functional test:

- Check for general damage
- Check of the fastener
- Check of the screw connection of the bracket to the footrest

## 8. SUPRA 2.0 operating life:

The expected operating life of the **SUPRA 2.0** is 5 years, depending on the intensity of use, care as well as maintenance. We recommend an annual inspection by the authorized specialist dealer.

In case of malfunctions or defects of the wheelchair, it must be immediately handed over to the medical supply store or the specialist dealer.

## 9. Specifications

	Frame size 1	Frame size 2	Frame size 3
<b>Seat width SUPRA 2.0</b>	300 - 340 mm	300 - 380 mm	300 - 440 mm
<b>Seat width SUPRA 2.0 Abdu</b>	240 - 340 mm	280 - 380 mm	280 - 380 mm
<b>Seat depth</b>	230 - 390 mm	240 - 440 mm	250 - 440 mm
<b>Back height</b>	200, 250, 300, 350 mm	200, 250, 300, 350 mm	200, 250, 300, 350 mm
<b>Seat height*</b> (front)	360 - 450 mm	380 - 470 mm	430 - 510 mm
<b>Seat angle</b>	approx. 0° up to 10°	approx. 0° up to 10°	approx. 0° up to 10°
<b>Backrest angle</b> (rigid back)	70° - 115°	70° - 115°	70° - 115°
<b>Backrest angle</b> (Back with relief position)	70° - 130°	70° - 130°	70° - 130°
<b>Lower leg length</b>	160 - 400 mm	190 - 410 mm	230 - 460 mm
<b>Footrest angle</b>	approx. +/- 10°	approx. +/- 10°	approx. +/- 10°
<b>Rear wheel diameter</b>	100, 125, 140 mm	100, 125, 140 mm	100, 125, 140 mm
<b>Camber</b>	3°, 6°, 9°	3°, 6°, 9°	3°, 6°, 9°
<b>Weight ***</b>	9,3 kg	9,9 kg	10,5 kg
<b>Total length</b> maximum / minimum	700 mm / 550 mm	780 mm / 610 mm	860 mm / 670 mm
<b>Total width</b> maximum / minimum	620 mm / 460 mm	680 mm / 460 mm	700 mm / 470 mm
<b>Height</b> maximum / minimum	670 mm / 530 mm	710 / 540 mm	750 mm / 550 mm
<b>Weight</b> (of the heaviest part)	6,1 kg	6,4 kg	6,8 kg
<b>Static stability</b> (to the front/back/side)	>10°	>10°	>10°
<b>User weight** / Maximum load based on the SW, NOT the frame size</b>	SW 24 - 32 = 60 kg	SW 34 - 38 = 80 kg	SW 40 - 44 = 100 kg
<b>Maximum inclination</b> (for use of the parking brakes)	10°	10°	10°
<b>Footrest hanger</b>	90°	90°	90°
<b>Minimum turning range</b>	1100 mm	1100 mm	1100 mm



### CAUTION!

\*The seat height depends on the frame size, the wheel diameter and the wheel camber.



### CAUTION!

\*\*Accessories and add-on parts reduce the remaining load capacity for the occupant.



### CAUTION!

\*\*\* The weight specifications refer to a **SUPRA 2.0** in basic equipment and maximum seat width.

---

HOGGI GmbH  
Eulerstraße 27 • 56235 Ransbach-Baumbach • Deutschland  
Telefon: (+49) 2623 / 92 499-0 •  
E-mail: [info@hoggi.de](mailto:info@hoggi.de) • [www.hoggi.de](http://www.hoggi.de)