HOGGI[®]



BINGO Evolution Service instructions

en

BINGO Evolution- Service and maintenance instructions

Content	Page
1 Model identification & basic configuration	
1.1 Model identification (label)	4
1.2 Basic configuration	4
2 Overview BINGO Evolution	5-12
3 Common information	14
3.1 Preface	14
3.2 Application	14
3.3 Declaration of conformity	14
3.4 Terms of warranty	14
3.5 Customer service	15
3.6 Service and repairs	15
3.7 Packing and shipping instructions	15
4 Safety Instructions	16
3.1 Meaning of symbols	16
3.2 Common safety instructions	16
5 Required tools and maintenance schedule	17
5.1 Required tools	17
5.2 Maintenance schedule	18-19
6 Seat settings	20
6.1 Seat height + lower leg length	20
6.2 Footrest angle	21
6.3 Seat width	21
6.4 Seat depth	22
6.5 Back height	22-23
6.6 Thorax width	23-24
6.7 Headrest width	24
6.8 Seat angle adjustment	25
6.9 Recline	25
7 Maintenance schedule	26
7.1 Chassis	26-27
7.2 Front strut	27
7.3 Rear frame	27
7.4 Rear axle	27
7.5 Push bar	28
7.6 Seat bearing	28
7.7 Front wheels	29
7.8 Rear wheels	30
7.9 Accessory bag	30
7.10 Braking system	30-31

7.11	Tie down kit _____	31
7.12	Swivel lock _____	32
7.13	Seat base _____	32
7.14	Seating surface _____	32
7.15	Thigh supports _____	32
7.16	Hip supports _____	33
7.17	Lateral supports _____	33
7.18	Back base _____	33-34
7.19	Back insert _____	34
7.20	Individual upholstery system _____	35
7.21	Footrest hanger _____	35
7.22	Footrest holder _____	35-36
7.23	Footrests _____	36
7.24	Headrest pads _____	36-37
7.25	Thorax pads _____	37
7.26	Belt fixations _____	37-38
7.27	Abduction block _____	38
7.28	Grab rail _____	39
7.29	Therapy tray _____	39
7.30	Retainer for accessories _____	39
7.31	Winter warmer _____	39
7.32	Canopy _____	40
8	Operating life _____	41
9	Specifications _____	41-42

1 Model identification

1.1 Model identification (label)

The **BINGO Evolution** mobility base label is mounted on the inside of the left side strut and under the seat panel.

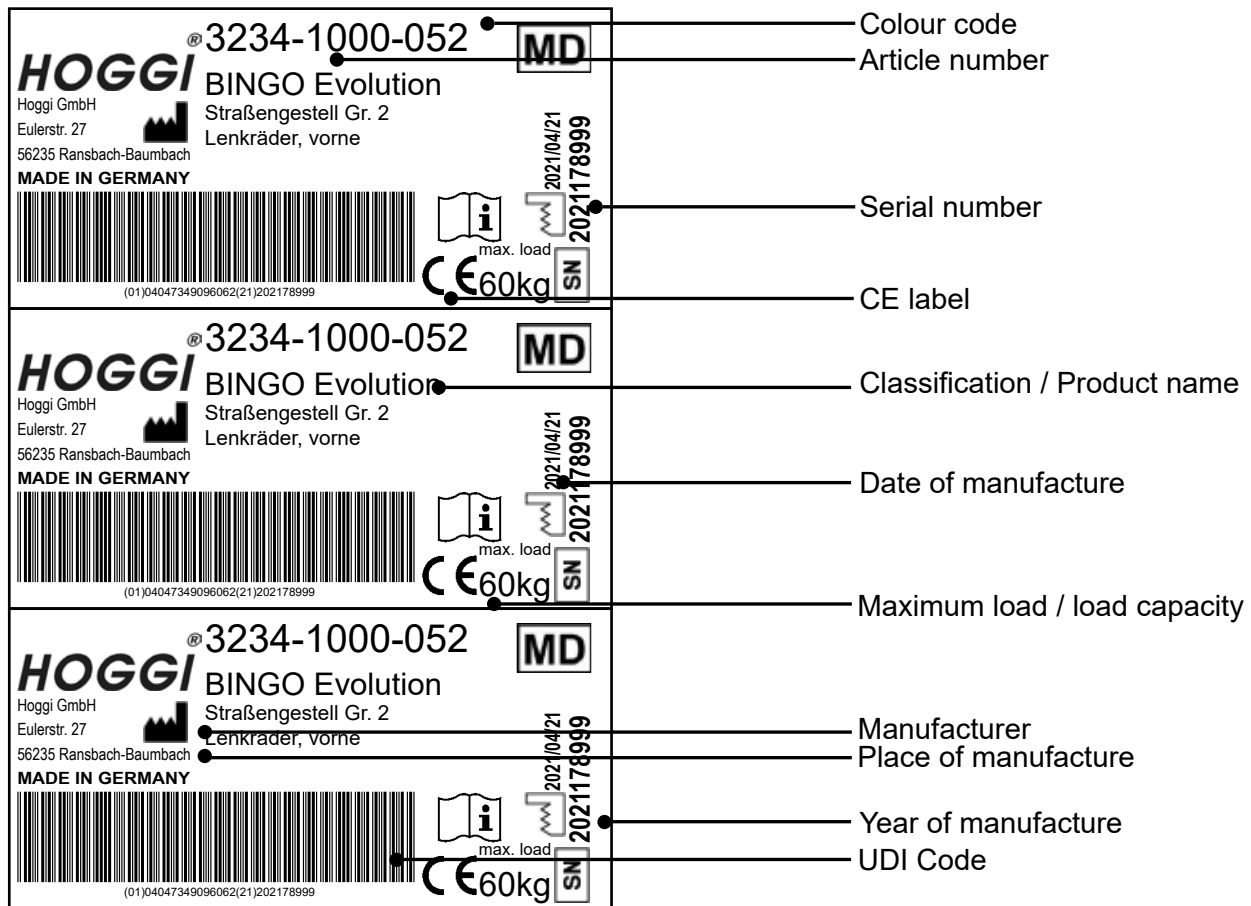

1.2 Basic configuration

- Bingo Evolution rehab pushchair (Mobility base and seat unit)
- Front and rear wheels with air or PU tires
- Padding (IUS)
- Thigh supports
- Footrest hanger
- Foot rest bracket und footrest

2 Overview BINGO Evolution

2.1 Mobility base, swiveling

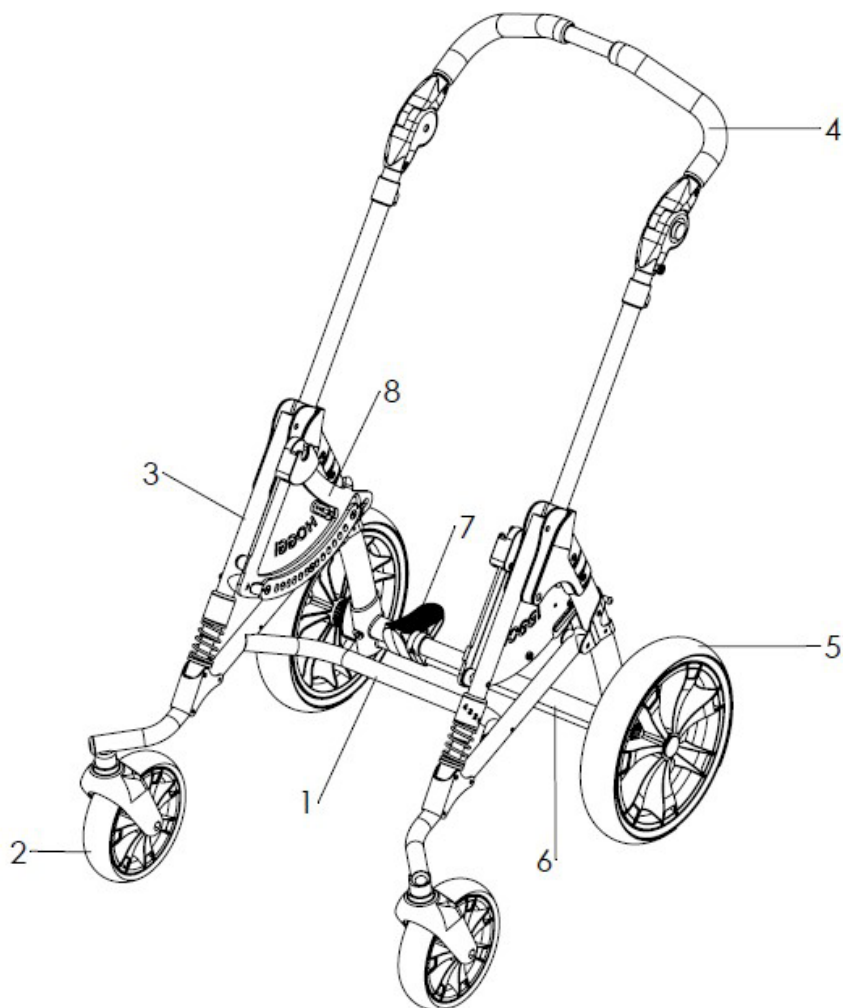

Pos	Article number	Articel description
1-8	3232-1011-032	BINGO-Evolution mobility base mini, swivelling front wheels
	3232-1000-xxx	BINGO-Evolution mobility base size 1, swivelling front wheels
	3234-1000-xxx	BINGO-Evolution mobility base size 2, swivelling front wheels
	3235-1000-xxx	BINGO-Evolution mobility base size 2XL, swivelling front wheels
1	3232-1100E-xxx	Frame size 1 (swivelling front wheels)
	3234-1100E-xxx	Frame size 2 (swivelling front wheels)
2	12xx-	Front wheel
3	3231-1300E-xxx	Front bar
	3231-7400E-xxx	Frame suspension system
4	3231-1400E-xxx	Push handle size 1
	3233-1400E-xxx	Push handle size 2
	3235-1400E-xxx	Push handle size 2XL
5	12xx-	Rear wheel
6	3231-1200E-xxx	Rear frame size 1
	3233-1200E-xxx	Rear frame size 2
7	3201-1301E-xxx	Brake size 1
	3203-1301E-xxx	Brake size 2
8	3230-1510E-032	Seat bearing mini left
	3230-1520E-032	Seat bearing mini right
	3231-1510E-xxx	Seat bearing size 1 and 2, left
	3231-1520E-xxx	Seat bearing size 1 and 2, right
	3235-1510E-xxx	Seat bearing size 2XL, left
	3235-1520E-xxx	Seat bearing size 2XL, right

2.2 Mobility base, rigid

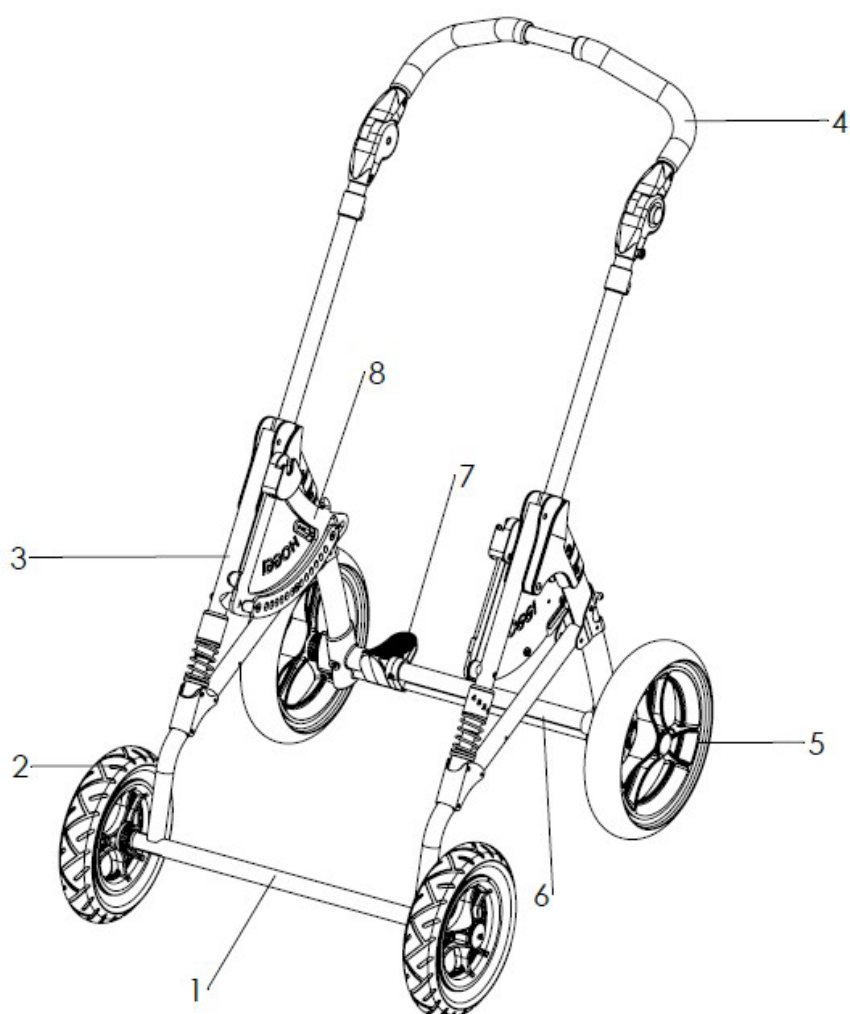

Pos	Article number	Articel description
1-8	3231-1011-032	BINGO Evo mobility base, with rigid front wheels Mini
	3231-1000-xxx	BINGO Evo mobility base, with rigid front wheels size 1
	3233-1000-xxx	BINGO Evo mobility base, with rigid front wheels size 2
1	3231-1100E-xxx	Frame size 1, rigid front wheels
	3233-1100E-xxx	Frame size 2, rigid front wheels
2	12xx-	Front wheel
3	3231-1300E-xxx	Front bar
	3231-7400E-xxx	Frame suspension system
4	3231-1400E-xxx	Push handle size 1
	3233-1400E-xxx	Push handle size 2
5	12xx-	Rear wheel
6	3231-1200E-xxx	Rear frame size 1
	3233-1200E-xxx	Rear frame size 2
7	3201-1301E-xxx	Brake size 1
	3203-1301E-xxx	Brake size 2
8	3231-1510E-xxx	Bearing (seat), left
	3231-1520E-xxx	Bearing (seat), right
	3230-1510E	Bearing (seat), Mini left
	3230-1520E	Bearing (seat), Mini right

2.3 Mobility base for respiratory equipment

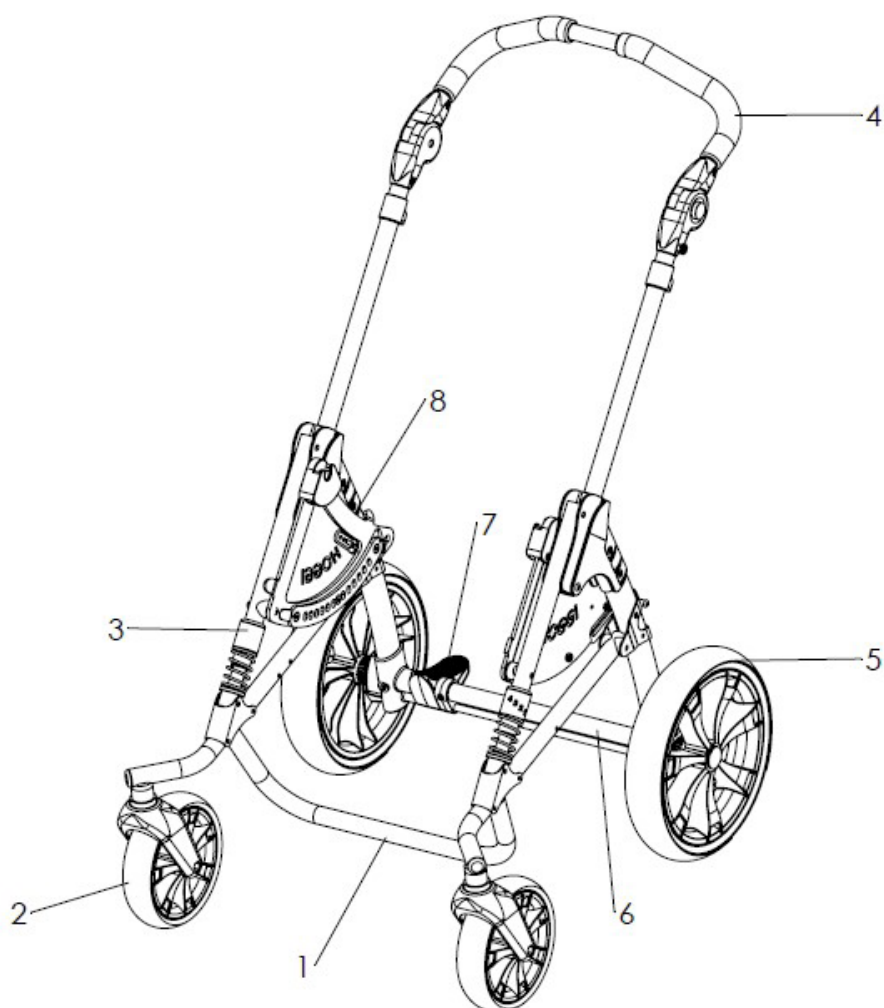

Pos	Article number	Articel description
1-8	3238-1011-032	BINGO Evo mobility base for additional equipment Mini
	3238-1000-xxx	BINGO Evo mobility base for additional equipment size 1
	3239-1000-xxx	BINGO Evo mobility base for additional equipment size 2
	3239-1006-xxx	BINGO Evo mobility base for additional equipment size 2XL
1	3238-1100E-xxx	Frame size 1 (for additional equipmen)
	3239-1100E-xxx	Frame size 2 (for additional equipmen)
2	12xx-	Front wheel
3	3231-1300E-xxx	Front bar
	3231-7400E-xxx	Frame suspension system
4	3231-1400E-xxx	Push handle size 1
	3233-1400E-xxx	Push handle size 2
	3235-1400E-xxx	Push handle size 2XL
5	12xx-	Rear wheel
6	3231-1200E-xxx	Rear frame size 1
	3233-1200E-xxx	Rear frame size 2
7	3201-1301E-xxx	Rear frame size 1
	3203-1301E-xxx	Brake size 2
8	3230-1510-032	Seat bearing mini, left
	3230-1520-032	Seat bearing mini, right
	3231-1510E-xxx	Seat bearing size 1 and 2, left
	3231-1520E-xxx	Seat bearing size 1 and 2, right
	3235-1510E-xxx	Seat bearing size 2XL, left
	3235-1520E-xxx	Seat bearing size 2XL, right

2.4 Mobility base Trike

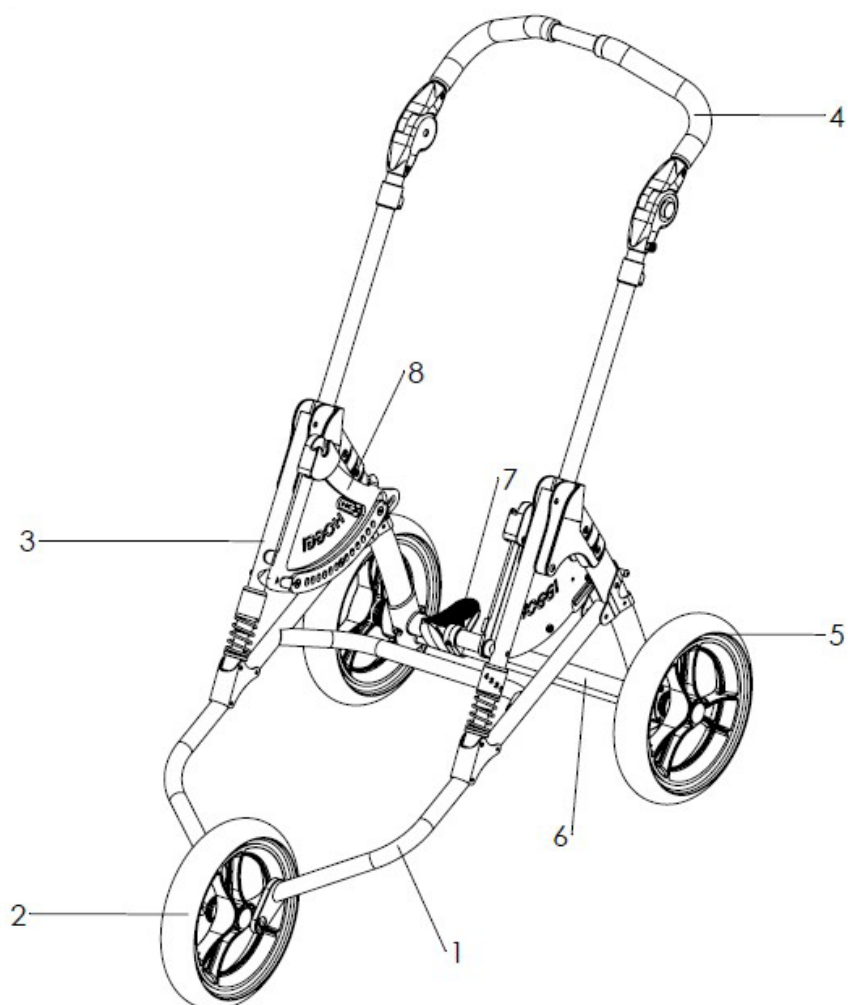

Pos	Article number	Articel description
1-8	3236-1011-032	BINGO-Evolution mobility base trike Mini,
	3236-1000-xxx	BINGO-Evolution mobility base trike size 1
	3237-1000-xxx	BINGO-Evolution mobility base trike size 2
1-3	3236-1100E-xxx	Frame size 1 (swivelling front wheels)
	3237-1100E-xxx	Frame size 2 (swivelling front wheels)
2	12xx-	Front wheel
3	3231-1300E-xxx	Front bar
	3231-7400E-xxx	Frame suspension system
4	3231-1400E-xxx	Push handle size 1
	3233-1400E-xxx	Push handle size 2
5	12xx-	Rear wheel
6	3231-1200E-xxx	Rear frame size 1
	3233-1200E-xxx	Rear frame size 2
7	3201-1301E-xxx	Brake size 1
	3203-1301E-xxx	Brake size 2
8	3230-1510E-xxx	Seat bearing, Mini left
	3230-1520E-xxx	Seat bearing, Mini right
	3231-1510E-xxx	Seat bearing size 1 and 2, left
	3231-1520E-xxx	Seat bearing size 1 and 2, right

2.5 Mobility base mini

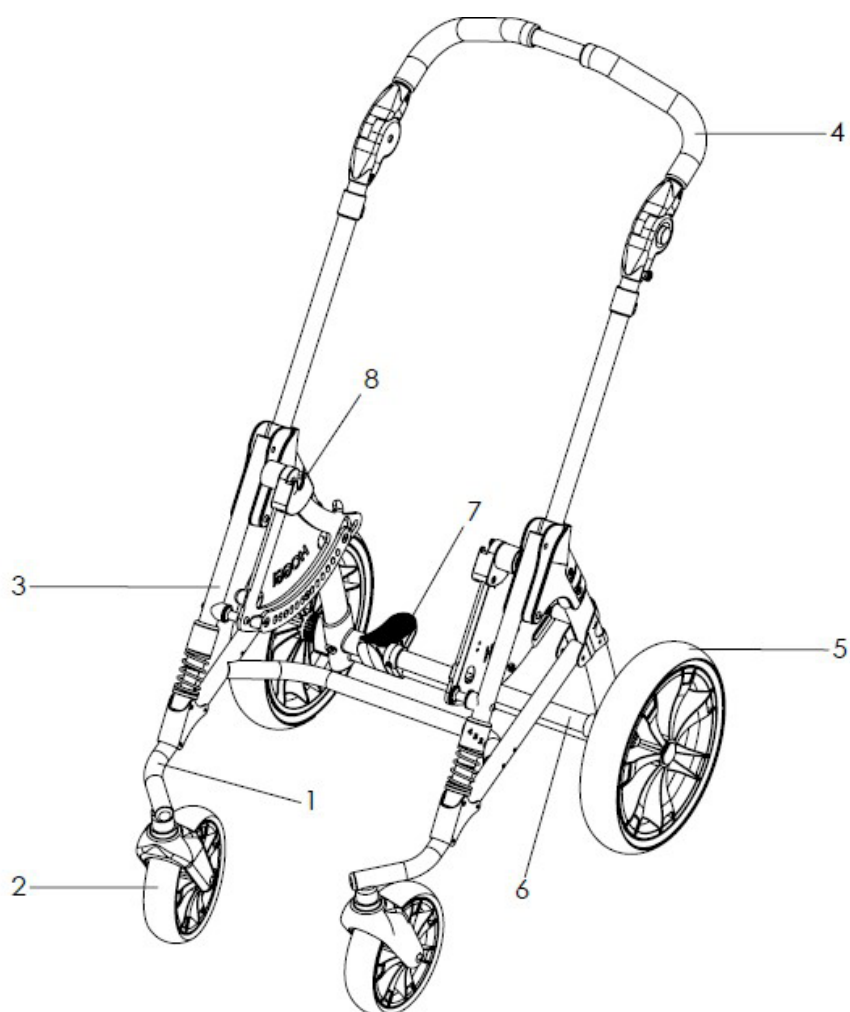

Pos	Article number	Articel description
1-8	3230-1000-032	BINGO-Evolution mobility base Mini (invert), swivelling front wheels
1	3230-1100E-032	Frame Mini invert (swivelling front wheels)
2	12xx-	Front wheel
3	3231-1300-032	Front bar
	3231-7400E-032	Frame suspension system
4	3231-1400-032	Push handle size 1
5	12xx-	Rear wheel
6	3230-1200E-032	Rear frame size 1
7	3201-1301E-032	Rear frame size 1
8	3230-1510E-xxx	Bearing (seat), Mini left
	3230-1520E-xxx	Bearing (seat), Mini right

2.6 Mobility base Cross



2.7 Seat unit

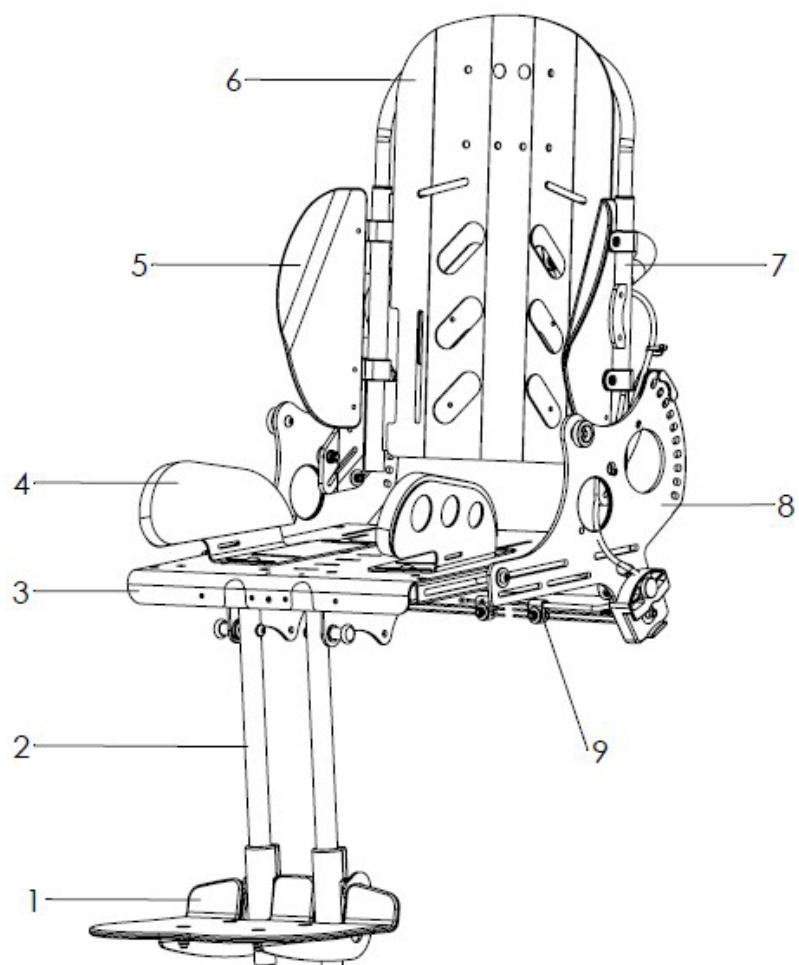

Pos	Article number	Articel description
1-9	3232-2000-xxx	Seat unit size 1
	3234-2000-xxx	Seat unit size 2
	3235-2000-xxx	Seat unit size 2XL
1	323X-2XXXE	Foot board
2	323X-2X00E-xxx	Footrest hanger
3	323X-2200-xxx	Seat surface
4	323X-2900E-xxx	Thigh support
	323X-2600E-xxx	Hip support
5	323X-27XX	Lateral support
6	323X-2800E-xxx	Back insert
7	323X-2300E-xxx	Back base
8	323X-2100E-xxx	Seat base
9	3231-1900E	Tilt mechanism

2.8 Seat unit mini

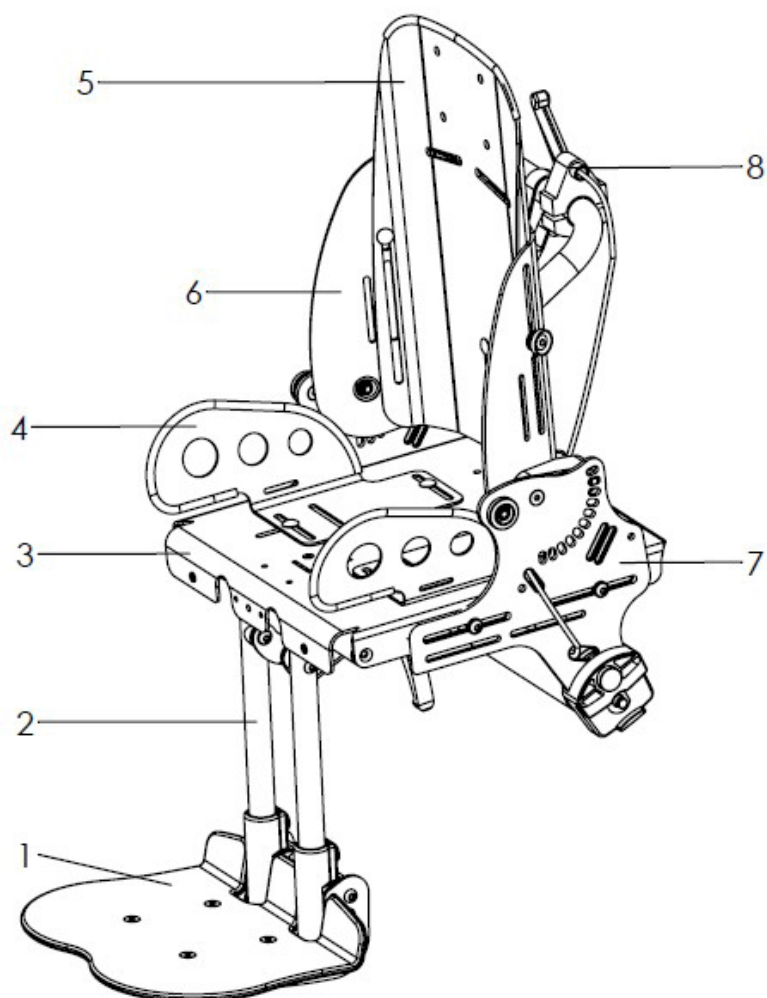

Pos	Article number	Articel description
1-6	3230-2000-032	Seat unit Mini
1	323X-2XXXE	Foot board
2	3230-2400-032	Footrest hanger
3	3230-2200E-032	Seat surface
4	3230-290X-032	Thigh support
	3230-2600E-032	Hip support
5	3230-2302E-032	Back insert
6	3230-2301E-032	Back base
7	3230-2100E-032	Seat base
8	3230-1900E	Tilt mechanism

3 Common Information

3.1 Preface

Thank you for selecting the **BINGO Evolution** rehab pushchair. We have designed this high-quality product to make your life safer and easier, and we've included this manual to help you use and care for it.

Please read the following instructions to make sure you use this product as recommended. If you have any further questions, or if you have any problems, please contact your healthcare provider.

We hope that **BINGO Evolution** meets your expectations.

We reserve technical modifications regarding the specified model in this manual. Before using the rehab pushchair the first time, this manual has to be read and understood by patient and support personnel in order to ensure a safe handling with the rehab pushchair.

Regular maintenance is important - it increases safety and prolongs the life of the product. Every rehab product should be checked and serviced once a year.

However, it is recommended to check, readjust and, if necessary, service products with a high frequency of use, with users in growth or users with a changing clinical picture at 6-month intervals.

Only original spare parts should be used for all service and maintenance work.

The service and maintenance work described here should only be carried out by trained specialist personnel and not by the user of the aid.

These service and maintenance instructions refer to the respective spare parts catalogs and operating instructions of the products described. Please use all documents together.

Use the maintenance schedule (Chapter 5.2, Checklist to tick off) as a copy template.

Retain completed maintenance schedules and provide a copy to the customer.

Bingo Evolution	User manual	1910-0030-EN
------------------------	-------------	--------------

Bingo Evolution	Spare parts catalog	1910-1006-EN
------------------------	---------------------	--------------

3.2 Application

Rehab pushchairs, paediatric postural positioning systems or strollers are appropriate for children and adolescents who are unable to walk or who have a walking impediment and thus requiring mobility assistance.

Assistance may be required due to:

- Atypical muscle tone
- Loss of limbs (dysmelia/lower limb amputation)
- Limb defect and / or deformity
- Joint contractures
- Joint defects
- General weakness

The **BINGO Evolution** rehab pushchair is able to be used indoor and outdoor as well as for further service. For further service the product has to be cleaned and sanitised efficiently. Afterwards the product has to be checked concerning condition, wearout and damage by an authorised technician. All damaged and inappropriate parts need to be changed. Please see also the service manual for detailed information.

3.3 2.3 Declaration of Conformity

HOGGI GmbH as manufacturer declares under sole responsibility that the rehab-pushchair for kids and adolescents **BINGO Evolution** meets the general safety and performance requirements to Annex I of the Regulation (EU) 2017/745 of the European Parliament and of the Council. Harmonised European Standards have been applied. Applicable harmonized standards have been applied. **BINGO Evolution** meets the requirements of ISO 7176-8, DIN EN ISO 12182 and DIN EN ISO 12183.

3.4 Terms of Warranty

Warranty applies only when the product is used according to the specified conditions and for the intended purposes, following all manufacturer's recommendations. The manufacturer is not responsible for damages caused by components and spare parts not approved by the manufacturer. See also § 8 of terms and conditions on: www.hoggi.de

3.5 Customer service

Our customer service will be happy to answer any technical questions you may have. Please refer to the last page for contact addresses and telephone numbers.

3.6 Service and repairs

Service and repairs on the **BINGO Evolution** rehab pushchair may only be carried out by your specialist dealer. In case of problems, contact your responsible specialist dealer. In case of repairs, you will only receive original spare parts there. Spare parts and replacement units are available during the entire service life of the product, but only for a maximum of 2 years after the sale of the last product in this series.

The wheelchair is custom made for the first time user. Therefore, no replacement wheelchair is available in the initial configuration. In order to ensure a correct spare parts delivery the serial no. of your wheelchair is required. We are happy to help you find a dealer near you.

You can reach us at: info@hoggi.de

3.7 Packing and shipping instructions

If **BINGO Evolution** has to be sent back to the manufacturer for repair or exchange the product must be thoroughly cleaned/disinfected beforehand and put in a hygienically safe condition.

Packaging is done by wrapping the product in a clean film, ideally with air cushions and the subsequent use of a sufficiently large cardboard box, so that no transport damage can occur.

4 Safety instructions

4.1 Meaning of symbols



Caution!
Warning of possible danger of accident and injury. Warning of possible technical damage.



Information!
About use of product.



Information!
For service-personnel.



Attention!
Read manual before use!

4.2 Common safety instructions

For all maintenance and repair work, you should generally observe a few points:



Attention!
Familiarize yourself with the functions of the product. If you are not familiar with the product, study the user manual before testing. If no user manuals are available, request them from us. You can also download documents from our homepage at: www.hoggi.de



Attention!
Study the service and maintenance instructions before starting work.



Attention!
Use suitable tools (see page 4 ff.).



Attention!
Wear suitable clothing and, if necessary, gloves and protective goggles.



Attention!
Secure the product from tipping over or falling down, e.g. from the workbench.



Attention!
Clean / disinfect the product before starting the test. If necessary, observe the instructions in the user manual and product-specific test instructions.



Note!
Screws and nuts with thread locking are used for a large number of screw connections. If you have to open such screw connections, replace the respective nut or screw with one with new thread locking. If new nuts or bolts with thread locking are not available, use liquid thread locking compound with medium strength (e.g. Loctite 241 or Euro Lock A24.20).

5 Required tools and maintenance schedule

5.1 Required tools

The following list shows the tools and utilities required for service.



Reversible ratchet and sockets
size 8-24



Torque wrench
Measuring ranges 5-50 Nm



Wrench
Size 6 - 24



Hexagon wrench
Gr. 3 - 6



Screwdriver
Blade width 2.5 3.5 and 5.5



Phillips screwdriver
Size 2



Plastic hammer



Hammer approx. 300 g



Carpet knife with sickle and
standard blade



Side cutter



Liquid thread locking
„medium strength“



Riveting pliers for rivets up to
5 mm

5.2 Maintenance schedule		BINGO Evolution Mobility base		Customer:	
Pos.	Area	Check (Checklist to tick off <input checked="" type="checkbox"/>)			
	Serial number:	1.) Function / Setting (siehe Bedienungsanleitung)	2.) none damage / deformation	3.) Screw connections	
Mobility base					
1.1	Front frame (Variants)		<input type="checkbox"/>	<input type="checkbox"/>	<input type="checkbox"/>
1.2	Front struts	- Suspension	<input type="checkbox"/>	<input type="checkbox"/>	<input type="checkbox"/>
1.3	Rear frame			<input type="checkbox"/>	<input type="checkbox"/>
1.4	Brake with rear axle	- Parking brake	<input type="checkbox"/>	<input type="checkbox"/>	<input type="checkbox"/>
1.5	Push bar	- Folding mechanism - Locking - Angle adjustment of the push handle	<input type="checkbox"/> <input type="checkbox"/> <input type="checkbox"/>	<input type="checkbox"/> <input type="checkbox"/> <input type="checkbox"/>	<input type="checkbox"/> <input type="checkbox"/> <input type="checkbox"/>
1.6	Seat bearing		<input type="checkbox"/>	<input type="checkbox"/>	<input type="checkbox"/>
1.7	Front wheels, rigid	- Tires - Air pressure - Running behavior of the wheels - Quick release	<input type="checkbox"/> <input type="checkbox"/> <input type="checkbox"/> <input type="checkbox"/>	<input type="checkbox"/> <input type="checkbox"/> <input type="checkbox"/> <input type="checkbox"/>	<input type="checkbox"/> <input type="checkbox"/> <input type="checkbox"/> <input type="checkbox"/>
	Front wheels, steerable - additional	- Swiveling the wheel forks	<input type="checkbox"/>	<input type="checkbox"/>	<input type="checkbox"/>
1.8	Rear wheels	- Tires - Air pressure - Running behavior of the wheels - Quick release	<input type="checkbox"/> <input type="checkbox"/> <input type="checkbox"/> <input type="checkbox"/>	<input type="checkbox"/> <input type="checkbox"/> <input type="checkbox"/> <input type="checkbox"/>	<input type="checkbox"/> <input type="checkbox"/> <input type="checkbox"/> <input type="checkbox"/>
Accessories					
1.9	Accessories bag	- Fold with	<input type="checkbox"/>	<input type="checkbox"/>	<input type="checkbox"/>
1.10	Braking system	- Brakes	<input type="checkbox"/>	<input type="checkbox"/>	<input type="checkbox"/>
1.11	Tie down kit			<input type="checkbox"/>	<input type="checkbox"/>
1.12	Swivel lock	- Locking device - Straight run	<input type="checkbox"/> <input type="checkbox"/>	<input type="checkbox"/> <input type="checkbox"/>	<input type="checkbox"/> <input type="checkbox"/>
	Do the settings on the base frame meet the user's requirements?		<input type="checkbox"/>		
Notes:					
The maintenance was performed by: on:					

5.2 Maintenance schedule		BINGO Evolution Seat unit		Customer:	
Pos.	Area	Check (Checklist to tick off <input checked="" type="checkbox"/>)			
	Serial number:	1.) Function / Setting (siehe Bedienungsanleitung)	2.) none damage / deformation	3.) Screw connections	
Seat unit					
2.1	Seat base	- Seat angle adjustment - Seat lock	<input type="checkbox"/> <input type="checkbox"/>	<input type="checkbox"/> <input type="checkbox"/>	<input type="checkbox"/> <input type="checkbox"/>
2.2	Seat	- Seat depth adjustment	<input type="checkbox"/>	<input type="checkbox"/>	<input type="checkbox"/>
2.3	Thigh support	- Seat width adjustment	<input type="checkbox"/>	<input type="checkbox"/>	<input type="checkbox"/>
	Hip support	- Seat width adjustment - Depth adjustment hip supports - Remove	<input type="checkbox"/> <input type="checkbox"/> <input type="checkbox"/>	<input type="checkbox"/>	<input type="checkbox"/> <input type="checkbox"/>
2.4	Lateral support	- Fold / Remove	<input type="checkbox"/>	<input type="checkbox"/>	<input type="checkbox"/>
2.5	Back base	- Recline	<input type="checkbox"/>	<input type="checkbox"/>	<input type="checkbox"/>
2.6	Back insertion	- Back height adjustment	<input type="checkbox"/>	<input type="checkbox"/>	<input type="checkbox"/>
2.7	all upholstery parts			<input type="checkbox"/>	
2.7	Footrest hanger 90°	- Snap-in mechanism 90°	<input type="checkbox"/>	<input type="checkbox"/>	<input type="checkbox"/>
	Footrest hanger 90°-160°	- Angle adjustment	<input type="checkbox"/>	<input type="checkbox"/>	<input type="checkbox"/>
2.8	Footrest	- Height adjustment - Angle adjustment - Locking (optional)	<input type="checkbox"/> <input type="checkbox"/> <input type="checkbox"/>	<input type="checkbox"/>	<input type="checkbox"/>
Accessories					
2.9	Headrest pads	- Width adjustment	<input type="checkbox"/>	<input type="checkbox"/>	<input type="checkbox"/>
2.10	Thorax support	- Width & height adjustment	<input type="checkbox"/>	<input type="checkbox"/>	<input type="checkbox"/>
2.11	Belt fixings: Lap belt, five-point harness, foot belts, ankle huger, groin strap, fixation jacket, chest-shoulder pad	- Closures	<input type="checkbox"/>	<input type="checkbox"/>	<input type="checkbox"/>
2.12	Pelvic bracket (accessories)	- Locking of the toothed belts	<input type="checkbox"/>	<input type="checkbox"/>	<input type="checkbox"/>
2.13	Abduction block (accessories)			<input type="checkbox"/>	<input type="checkbox"/>
2.14	Grab rail (accessories)	- Locking (tripod springs)	<input type="checkbox"/>	<input type="checkbox"/>	<input type="checkbox"/>
2.15	Therapy tray (accessories)	- Locking (tripod springs) - Angle adjustment - Depth adjustment	<input type="checkbox"/> <input type="checkbox"/> <input type="checkbox"/>	<input type="checkbox"/>	<input type="checkbox"/>
2.16	Canopies (accessories)	- Angle adjustment of canopy - Plug connection to the adapter	<input type="checkbox"/> <input type="checkbox"/>	<input type="checkbox"/>	<input type="checkbox"/>
	Do the seat unit settings meet the user's requirements?		<input type="checkbox"/>		
Notes:					
The maintenance was performed by: on:					

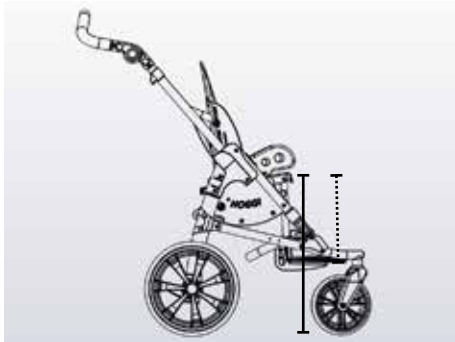

6. Seat settings

6.1 Seat height & lower leg length

The front seat height is approx. 47 cm with the seat in a straight position. Adjustable lower leg lengths vary depending on size.

Size mini:	16 - 34 cm
Size 1:	16 - 37 cm
Size 2:	16 - 40 cm
Size 2XL:	16 - 40 cm



However, with the adapter shown, the seat height can be increased by 10 cm.

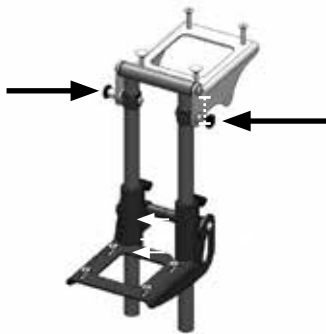

Lower leg length

BINGO Evolution can basically be equipped with 2 different footrest hanger.

Shown here is the footrest hanger 90°

The footrest hanger can be swiveled up via the tension catches, but not fixed in place.



Footrest hanger angle adjustable

Adjustable between 85° and 170° via clamping lever.

Minimum LLL 19 cm
Standard for BINGO Evolution mini



The height adjustment of the footrest is done by loosening the wing nuts on the back.

Thereupon, the respective footrest mounted on the carrier, can be adjusted to the individual needs.



6.2 Footrest angle

The footrest angle is preset to 90°. The adjustment range is +/- 10° (80° - 100°).

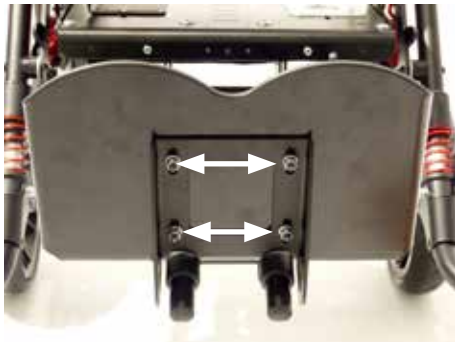

After loosening the four marked screw connections on the footrest holder the footrest can be adjusted in depth.

This changes the anchor point of the footrest and thus also the footrest angle. The further the footrest is pulled out to the front, the the greater the angle. If the procedure is reversed the angle decreases accordingly.

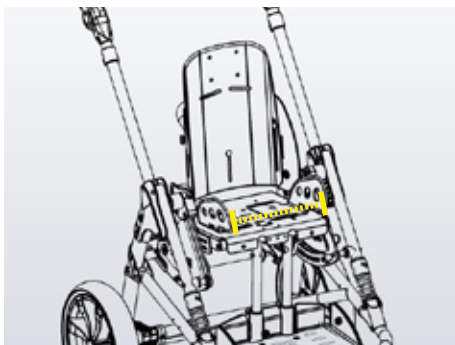

6.3 Seat width

The seat width of the BINGO Evolution can be adjusted by moving the the thigh - or the hip supports.

The following adjustment ranges result for the four sizes:

Size mini:	13 - 25 cm
Size 1:	18 - 30 cm
Size 2:	23 - 35 cm
Size 2XL:	23 - 35 cm

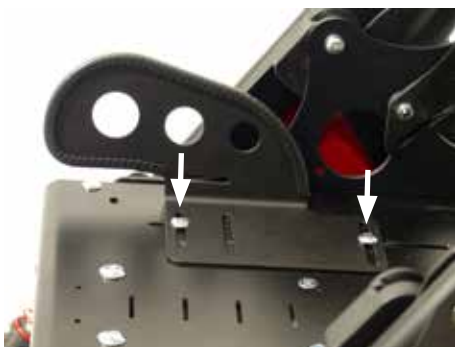

The pad is secured to the seat panel by a screw connection. The desired seat widths can be achieved by shifting in 2 slotted holes. In addition, the depth positioning can be adjusted.



Wing nut screws on the underside of the seat plate secure the connection. An additionally attached nut serves as protection against loss and should always be mounted.



6.4 Seat depth

Bingo Evolution offers an enormous ability to grow with the seat depth. The following adjustment ranges result for the four sizes:

Size mini: 12 - 27 cm
 Size 1: 16 - 34 cm
 Size 2: 22 - 40 cm
 Size 2XL: 30 - 45 cm

Measuring point front edge of seat panel to back tube



In order to adjust the seat depth, a total of 4 screw connections must be loosened.

For this purpose, it is advisable to either separate the seat unit from the chassis or at least to unlock it in order to have all screw connections clearly visible.

First, the front screws are loosened.



The seat unit is then unlocked and the rear screws can be loosened.



The seat panel can now be adjusted to the desired depth position. Finally, tighten all screw connections again!

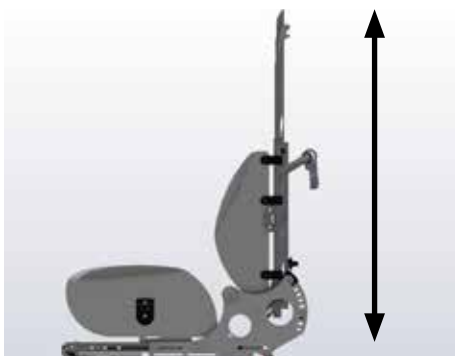

6.5 Back height

Depending on the size, BINGO Evolution offers different adjustable back heights.

Size mini: 37 - 51 cm
 Size 1: 45 - 63 cm
 Size 2: 54 - 75 cm
 Size 2XL: 62 - 83 cm

From back height >75 cm we recommend the long push bar top!



By opening the indicated wing nut screws, the upper back section can be pulled out or pushed in opposite the base. This applies to size 1, 2 and 2 XL

Back height low



Back telescoped

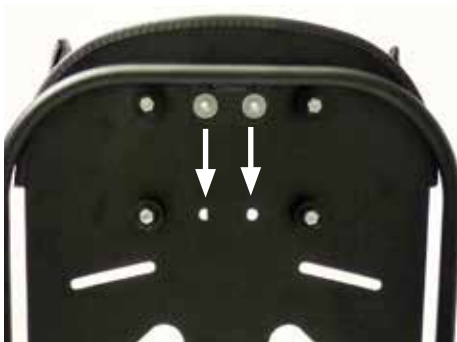

From a backrest height of 66 cm, the backrest bar must be set to the lower position for stability reasons.



For size mini, telescoping is triggered by a knurled nut.

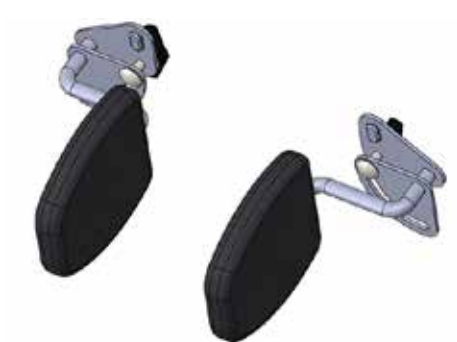

6.6 Width thorax

Optional thorax pelotte pads can be used to generate lateral upper body support. The pads can be adapted precisely to the user. They are adjustable in width, height and angle.



By loosening the indicated wing nut, the distance between both pads and also the height can be adjusted.

The minimum and maximum adjustable distance for the sizes:

Size mini: 10-20 cm
 Size 1: 12-22 cm
 Size 2 and 2XL: 17-27 cm

6.7 Width headrests

BINGO Evolution can be equipped with the standard headrests, as well as with a low form

Low form:

Provides a total adjustment range of 2 cm by sliding in 1 cm slotted holes in the pad support. Distance between supports:

Size mini: 12-14 cm
 Size 1: 14-16 cm
 Size 2 and 2XL: 18-20 cm



Standard:

In addition to the adjustment range in the beam, offers an additional adjustment possibility by gluing in 3x1 cm wide foam inserts per side.



Adjustment range of the slotted holes in the pad support.



3 foam inserts with self-adhesive film. If the inserts are glued to the inside of the pad support, the distance between the sides is reduced by 1 cm. This means that with a maximum of 6 inserts, the area can be additionally reduced by a total of 6 cm.

This results in for:

Size mini: 8-16 cm
 Size 1: 8-16 cm
 Size 2 and 2XL: 13-21 cm





6.8 Seat angle adjustment

The seat angle of the BINGO Evolution can be adjusted between 0° and 45° in 12 positions of 3.5° each.

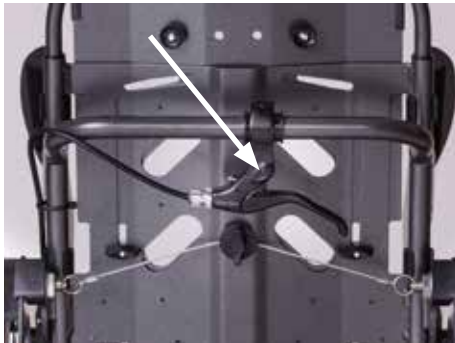

With the help of the adjustment lever on the back can be adjusted desired seating position.



6.9 Recline

Depending on the size, the back angle of BINGO Evolution can be adjusted between 80° and 180° in 10 positions.

Size mini: 80° - 180°
Size 1: 90° - 160°
Size 2: 90° - 160°
Size 2XL: 90° - 135°

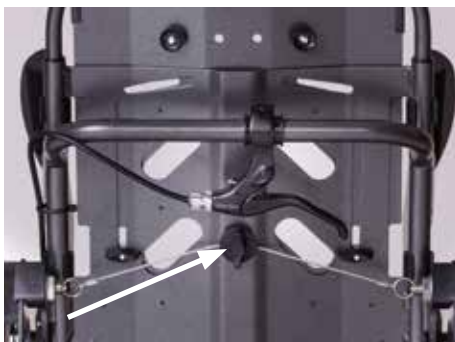

With the help of the rotary knob on the back, the desired seat position can be set.
For size mini, the mechanism is operated by a release cable instead of the knob.

7. Maintenance schedule

7.1 Chassis

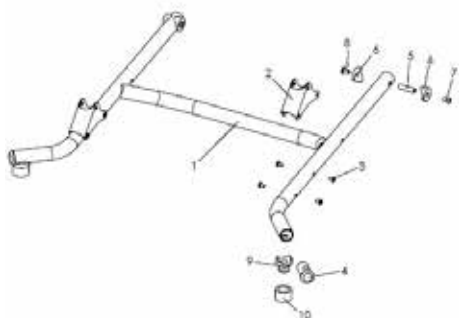

Steering wheel frame

- Check for general damage, bending
- Check of the screw connections to the rear axle, rear frame and front strut

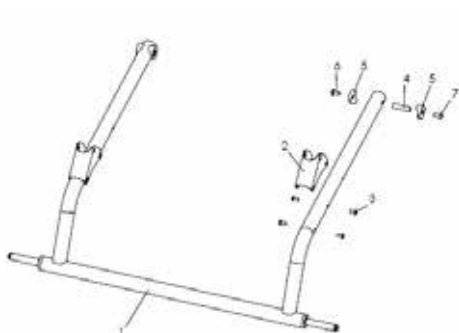

Rigid frame

- Check for general damage, bending
- Check of the screw connections to the rear axle, rear frame and front strut

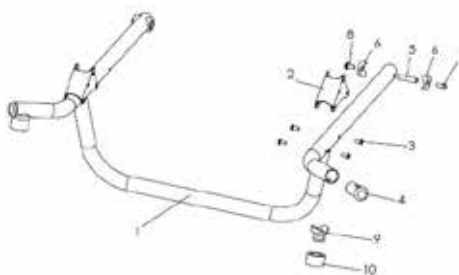

Steering wheel frame for respiratory equipment

- Check for general damage, bending
- Check of the screw connections to the rear axle, rear frame and front strut

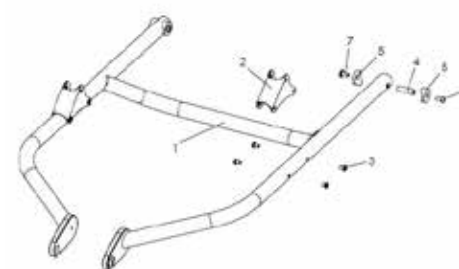

FrameTrike

- Check for general damage, bending
- Check of the screw connections to the rear axle, rear frame and front strut

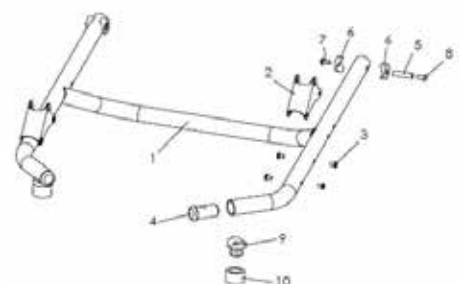

Frame mini

- Überprüfung auf allgemeine Beschädigungen, Verbiegungen
- Check of the screw connections to the rear axle, rear frame and front strut

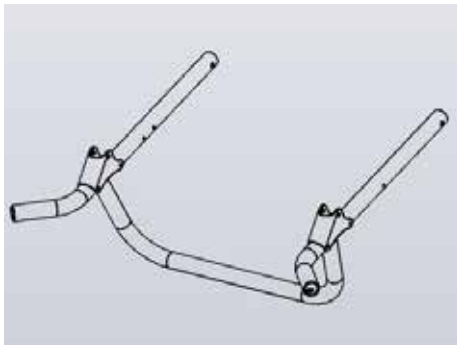

Frame Cross

- Check for general damage, bending
- Check of the screw connections to the rear axle, rear frame and front strut



7.2 Front strut

- Check for general damage, breakage of the spring
- Adjustment of the spring strength
- Suspension
- Check of the bolting to the frame and to the rear frame joint



- Check of the bolting to the front frame, to the rear frame joint and seat bearing plate



7.3 Rear frame

- Check for general damage
- Check of the screw connection to the rear frame joint
- Check of the screw connection to the joint bandage
- Check of the screw connection to the axle tube connector

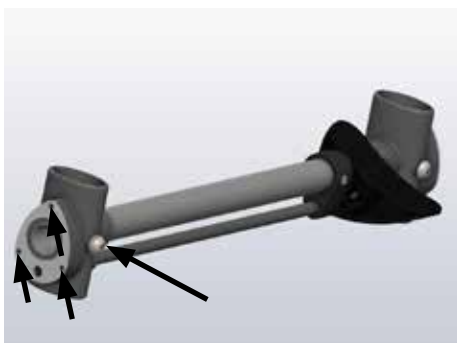

7.4 Rear axle

- Check for general damage
- Brake function of the parking brake
- Brake rod bearing and brake pedal retention
- Check of the screw connections to the booster plate and to the connector



7.5 Push bar

- Check for general damage
- Folding in via the release button
- Angle adjustment of the upper part of the push bar via the ratchet joints
- Latching of the push bail in unfolded state

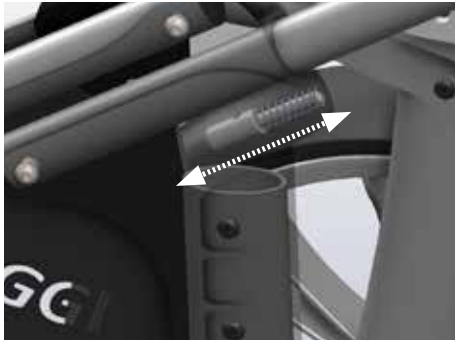

- Locking of the push bar in the unfolded state, bolt must release from the lock when folded and lock in the rear frame joint when unfolded.

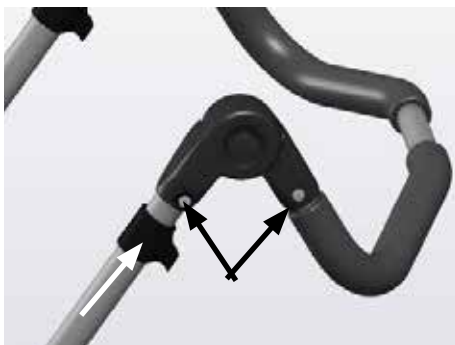

Check of the screw connections:

- Lower screw connection of the lower part of the push bar through the push bar joint to the rear frame joint
- Fastening of the release button
- Rivet connection of the ratchet joint

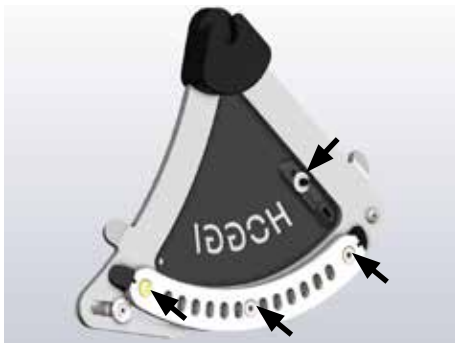

7.6 Seat bearing

- Check for general damage
- Insertion of the seat unit in the channel bearing
- Function of the release
- Seat tilt, locking of the bolts in the tilt skids

Check of the screw connections:

- Screwing of the edge runners to the seat bearing plate and side panel.
- Fastening of the release button



- Riveted connection of the channel bearing
- Front and rear bolting to the frame



7.7 Front wheels

rigid

- Check for general damage
- Check of the tread or profile (cracks, heavy wear)
- impurities
- Check of the air pressure of pneumatic tires



swiveling

- Plastic or aluminum steering fork
- Swiveling of the wheel forks
- Fluttering of the wheels (steering fork damping installed?)
- Check for general damage
- Check of the tread or profile (cracks, heavy wear)
- impurities
- Check of the air pressure of pneumatic tires



- Camber of the wheel worn too much

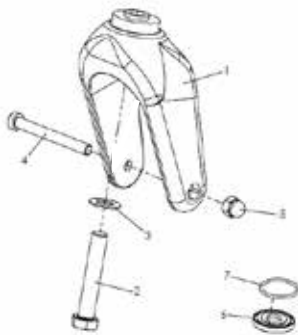

Check of the bolted connections:

- Screw connection of the wheel axle
- Bolting of the steering fork axle to the frame



Make sure that the steering fork is set up as follows!

The sealing washer with the O-ring prevents excessive „fluttering“ of the steering forks.

The screw must be tightened accordingly with 40 Nm!



7.8 Rear wheels

- Air or PU tires
- Check for general damage (storage)
- Running behavior of the wheels
- Check of the treads and the luddt pressure (if pneumatic tires)
- Check of the quick lock



7.9 Accessory bag

- 3 kg loadable
- Check for general damage
- Fastening points ok
- Can the bag be folded without problems



7.10 Braking system

BINGO Evolution can be equipped with 3 brake variants!

Parking brake:

- Basic configuration
- Not in combination with drum brake wheels
- Easily replaceable
- Locking when locked?
- Pivoting



Brake for attendant

- Check for general damage
 - Check of the brake levers
 - Check of the Bowden cable
- Check of the screw connection of the brake levers to the push bar



- Build-up of the brake pressure (readjustment of the adjusting screw)



- Wheel with aluminum brake disc
- Check of the holes (knocked out, broken bars)
 - Impurities



Drum brake

- Check for general damage
 - Check of the brake levers
 - Check of the red locking lever
 - Check of the Bowden cable
- Check of the screw connection of the brake levers to the push bar

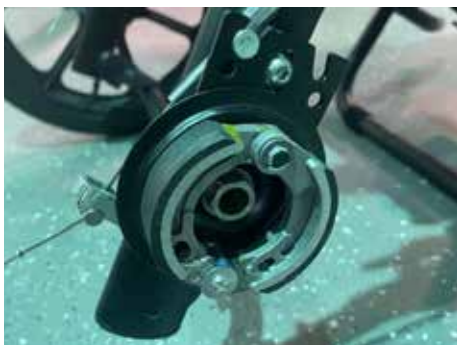

- Build-up of the brake pressure (readjustment of the adjusting screw)
- Contamination of the brake shoes



Check of the drum brake wheel



7.11 Tie down kit

- Check for general damage (deformation, sharp edges).
edges)
- Check of the screw connections to the frame and to the edge skid



7.12 Swivel lock

- Check for general damage
- Check of the latch
- Check of the straight run



7.13 Seat base

- Check for general damage
- Check of seat angle adjustment
- Check of seat lock



- Check of the screw connection to the cross strut

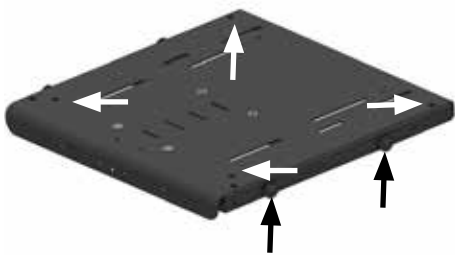

7.14 Seating surface

- Check for general damage
- Check of the seat depth adjustment
- Check of the screw connections from the seat panel to the seat frame
- If present, inspection of riveted connections or attached brackets for straps



7.15 Thigh supports

- Check for general damage
- Depth and width adjustment of the pad support
- Check of the screw connections to the seat panel



7.16 Hip supports

- Check for general damage
- Depth and width adjustment of the pad support
- Check of the screw connections to the seat panel



- Removing the hip support



7.17 Lateral supports

- Check for general damage
- Folding of the pads
- Removal via click connection



7.18 Back base

Back base Size 1/2/2XL

- Check for general damage
- Recline
- Check of the screw connection to the seat base



Back base mini

- Check for general damage
- Recline
- Check of the screw connection to the seat base



Back base BINGBO Evolution OT

- Check for general damage
- Recline
- Check of the screw connection to the seat base



Back base BINGBO Evolution OT Plus

- Check for general damage
- Recline
- Check of the screw connection to the seat base



7.19 Back insert

Size 1/2/2XL

- Check for general damage
- Damage to the edge protection
- Height adjustment / telescoping
- Removal of the slide-in unit
- Check of the screw connection for height adjustment



Back insert mini

- Check for general damage
- Damage to the edge protection
- Height adjustment / telescoping
- Removal of the slide-in unit
- Check of the screw connection for height adjustment



Back insert OT

- Check for general damage
- Height adjustment / telescoping
- Removal of the slide-in unit
- Check of the screw connection for height adjustment



7.20 Individual upholstery system

- Check for general damage or impurities
- Wear of the upholstered surfaces



7.21 Footrest hanger

Footrest hanger fixed

Functional test:

- Check for general damage
- Latching mechanism 90
- Distance to seat panel
- Screw connection to seat frame



Footrest hanger angle adjustable

Functional test:

- Check for general damage
- Swivel mechanism
- Clamping lever for angle adjustment
- Screw connection to seat frame



7.22 Footrest holder

Standard

Functional test:

- Height adjustment
- Check for general damage
- Swivel mechanism of the screwed footrest
- Correct adjustment of the foot angle
- Sliding of the holder on the tubes



With interlock

Functional test:

- Height adjustment
- Check for general damage
- Swivel mechanism of the screwed footrest
- Correct adjustment of the foot angle
- Sliding of the holder on the tubes
- Locking bolt pull with locking latches, tension of the rope

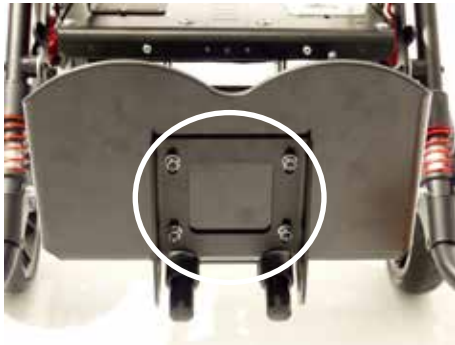

Check of the screw connections:

- Screw connection to the footrest with correct angle adjustment

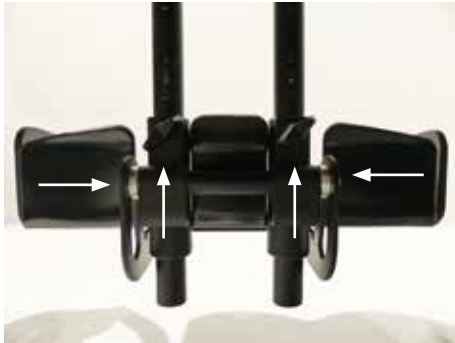

- Screws for lower leg length adjustment
- Screwing of the swivel mechanism



7.23 Footrests

Footrest standard with heel edge

Functional test:

- Check for general damage
- Screw connection to the footrest support



Footrest in boat form

Functional test:

- Check for general damage
- Screw connection to the footrest support



7.24 Headrest pads

Standard

- Check for general damage (Velcro fastening, seams, holes or strapped-through areas)
- Check for impurities
- Insertion pad
- Function of the width adjustment via the pad support



Low version:

- Check for general damage (Velcro fastening, seams, holes or strapped-through areas)
- Check for impurities
- Insertion pad
- Function of the width adjustment via the pad support

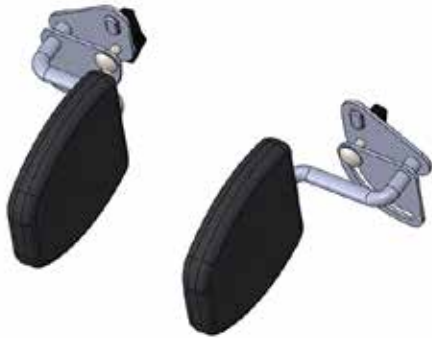

7.25 Thorax pads

- Check for general damage
- Height and angle adjustment via wing nut on the rear side
- Angle adjustment of the pelotte carrier from the front



7.26 Belt fixations

Lap belt

Functional test:

- Check for general damage
- Check of the fastener
- Check of the screw connection of the bracket



4-point lap belt

Functional test:

- Check for general damage
- Check of the fastener
- Check of the screw connection of the bracket



Ankle hugger

Functional test:

- Check for general damage
- Check of the fastener
- Check of the screw connection of the bracket to the footrest



Five-point harness

Functional test:

- Check for general damage
- Check of the fastener
- Check of the screw connection of the brackets



Groin strap

Functional test:

- Check for general damage
- Check of the fastener
- Check of the screw connection of the brackets



Fixation jacket

Functional test:

- Check for general damage
- Check of the fastener
- Check of the screw connection of the brackets
- Function of the buckles on the back panel
- Rivet connection of the clamping buckles



Chest-shoulder harness

Functional test:

- Check for general damage
- Check of the fastener
- Check of the screw connection of the brackets
- Function of the buckles on the back panel
- Rivet connection of the clamping buckles



7.27 Abduction block

Functional test:

- Check for general damage
- Pivoting and latching mechanism
- Removal

Check of the screw connections:

- Bracket abduction block to the seat panel



7.28 Grab rail

Functional test:

- Check for general damage
- Damage to the cover
- Check of the tripod springs and the anchoring in the retainer for accessories

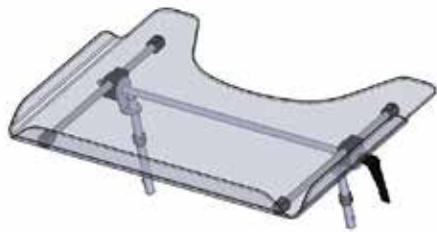

7.29 Therapy tray

Standard

Functional test:

- Check for general damage
- Damage of angle adjustment and depth adjustment
- Check of the tripod springs and the anchoring in the retainer for accessories

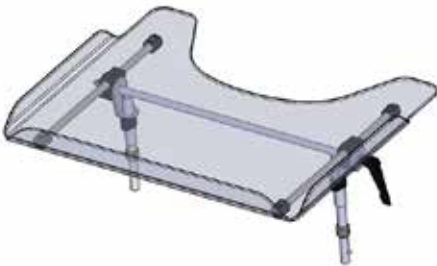

Height adjustable

Functional test:

- Check for general damage
- Damage of angle adjustment and depth adjustment
- Height adjustment
- Check of the tripod springs and the anchoring in the retainer for accessories

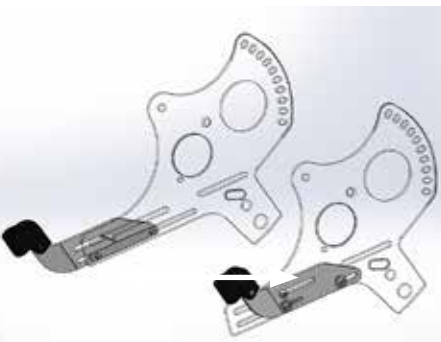

7.30 Retainer for accessories

Necessary for use of therapy tray or grab rail

- Check for general damage
- Screw connection of the bracket to the seat base



7.31 Winter warmer

Functional test:

- Check for general damage
- Zipper intact
- Damage to the real fur insert if present



7.32 Canopy

Functional test:

- Check for general damage
- Folding and unfolding of the canopy



- Removal via canopy adapter
- Checking the screw connections of the adapter to the back bar or to the back panel on BINGO Evolution mini

8. BINGO Evolution operating life:

The expected operating life of the **BINGO Evolution** is 5 years, depending on the intensity of use, care as well as maintenance. We recommend an annual inspection by the authorized specialist dealer.

In case of malfunctions or defects of the wheelchair, it must be immediately handed over to the medical supply store or the specialist dealer.

9. Specifications

	Mini	Size 1
Seat width	130 - 250 mm	180 - 300 mm
Seat depth	120 - 270 mm	160 - 340 mm
Tilt of seat unit Seat unit in driving direction Seat unit against driving direction	45° 45°	45° 45°
Back height	370 - 510 mm	450 - 630 mm
Recline Seat unit in driving direction Seat unit against driving direction	80° - 180° 80° - 180°	90° - 160° 90° - 160°
Lower leg length	160 - 340 mm	160 - 370 mm
Rear wheel diameter	290 x 60 mm 300 x 60 mm	290 x 60 mm 300 x 60 mm
Steering wheel diameter	190 x 50 mm 200 x 48 mm	190 x 50 mm 200 x 48 mm
User weight Maximum load* Seat unit Mobility base	25 kg 60 kg	50 kg 60 kg
Weight** Seat unit Mobility base	6,4 kg 8,6 kg	6,4 kg 8,6 kg
Total length Maximum Minimum	1015 mm 910 mm	1015 mm 910 mm
Total width Maximum Minimum	630 mm 620 mm	630 mm 620 mm
Height	1110 mm	1110 mm
Weight of the heaviest part (seat unit)	8,6 kg	8,6 kg



CAUTION!

*Accessories and add-on parts reduce the remaining load capacity for the occupant.



CAUTION!

The weight specifications refer to a **BINGO Evolution in basic equipment.

9. Specifications

	Size 2	Size 2 XL
Seat width	230 - 350 mm	230 - 350 mm
Seat depth	220 - 400 mm	300 - 450 mm
Tilt of seat unit Seat unit in driving direction Seat unit against driving direction	45° 45°	45° 45°
Back height	540 - 750 mm	620 - 830 mm
Recline Seat unit in driving direction Seat unit against driving direction	90° - 160° 90° - 160°	90° - 135° 90° - 135°
Lower leg length	160 - 400 mm	160 - 400 mm
Rear wheel diameter	290 x 60 mm 300 x 60 mm	290 x 60 mm 300 x 60 mm
Steering wheel diameter	190 x 50 mm 200 x 48 mm	190 x 50 mm 200 x 48 mm
User weight Maximum load* Seat unit Mobility base	50 kg 60 kg	50 kg 60 kg
Weight** Seat unit Mobility base	7,4 kg 8,7 kg	7,4 kg 8,7 kg
Total length Maximum Minimum	1015 mm 910 mm	1015 mm 910 mm
Total width Maximum Minimum	680 mm 670 mm	680 mm 670 mm
Height	1110 mm	1110 mm
Weight of the heaviest part (seat unit)	8,7 kg	8,7 kg

HOGGI GmbH
Eulerstraße 27 • 56235 Ransbach-Baumbach • Deutschland
Fon: (+49) 2623 / 92 499-0
E-mail: info@hoggi.de • www.hoggi.de